

22 January 1998

AGREEMENT

CONCERNING THE ADOPTION OF UNIFORM TECHNICAL PRESCRIPTIONS FOR WHEELED VEHICLES, EQUIPMENT AND PARTS WHICH CAN BE FITTED AND/OR BE USED ON WHEELED VEHICLES AND THE CONDITIONS FOR RECIPROCAL RECOGNITION OF APPROVALS GRANTED ON THE BASIS OF THESE PRESCRIPTIONS*/

(Revision 2, including the amendments entered into force on 16 October 1995)

Addendum 103: Regulation No. 104

Date of entry into force: 15 January 1998

UNIFORM PROVISIONS CONCERNING THE APPROVAL OF RETRO-REFLECTIVE MARKINGS FOR HEAVY AND LONG VEHICLES AND THEIR TRAILERS



UNITED NATIONS

*/ Former title of the Agreement:

Agreement Concerning the Adoption of Uniform Conditions of Approval and Reciprocal Recognition of Approval for Motor Vehicle Equipment and Parts, done at Geneva on 20 March 1958.

GE.98-20224

Regulation No. 104

UNIFORM PROVISIONS CONCERNING THE APPROVAL OF RETRO-REFLECTIVE MARKINGS FOR
HEAVY AND LONG VEHICLES AND THEIR TRAILERS

CONTENTS

REGULATION	<u>Page</u>
1. Scope	5
2. Definitions	5
3. Application for approval	7
4. Trade names and other marks	8
5. Approval	8
6. General specifications	9
7. Special specifications	10
8. Modifications and extension of approval for retro-reflective marking materials	10
9. Conformity of production	11
10. Penalties for non-conformity of production	11
11. Production definitely discontinued	12
12. Names and addresses of technical services responsible for conducting approval tests and of administrative departments	12

ANNEXES

- Annex 1 - The CIE co-ordinate system; Goniometer mechanism embodying the CIE angular system
- Annex 2 - Communication concerning the approval or extension or refusal or withdrawal of approval or production definitely discontinued of retro-reflective markings of heavy and long vehicles and their trailers pursuant to Regulation No. 104
- Annex 3 - Arrangement of the approval mark
- Annex 4 - Test procedure
- Annex 5 - Specification of marking dimensions

CONTENTS (cont'd)

Annex 6 - Colorimetric specifications

Annex 7 - Photometric specifications

Annex 8 - Resistance to external agents

Annex 9 - Guidelines for the marking shape and mounting requirements

Appendix 1 - Examples of retro-reflective markings with strips

Appendix 2 - Examples of retro-reflective contour markings (with distinctive markings and graphics)

1. SCOPE

These provisions apply to the approval of retro-reflective markings used to increase the visibility and recognition for heavy and long vehicles and their trailers.

2. DEFINITIONS

2.1. For the purpose of these provisions, the following definitions shall apply:

- 2.1.1. "Marking" means a rectangular strip or a series of such strips intended to be placed in such a way that it identifies the entire length and width of a motor vehicle and its trailer when viewed from the side (side marking) or rear (rear marking).
- 2.1.2. "Contour marking" means a series of strips intended to be placed in such a way that it shows the contour of the vehicle to the side (side marking) and to the rear (rear marking).
- 2.1.3. "Distinctive markings, Graphics" mean additional coloured markings intended to be placed within the contour marking, whose coefficient of retro-reflection is essentially lower than the coefficient of retro-reflective materials as defined in paragraphs 2.1.1. and 2.1.2.
- 2.1.4. "Sample unit" means part or all of the retro-reflective material intended to be used to achieve the markings defined in paragraphs 2.1.1., 2.1.2. and 2.1.3.
- 2.2. "Retro-reflection" means the reflection in which luminous flux is returned in directions close to the direction from which it came, this property being maintained even over wide variations of the direction of the luminous flux.
- 2.2.1. "Retro-reflective marking material" means a surface or a device from which, when directionally illuminated, a relatively large portion of the incident radiation is retro-reflected.
- 2.3. Geometric definitions (see annex 1, figure 1)
- 2.3.1. "Reference centre" means a point on or near a retro-reflective area which is designated to be the centre of the device for the purpose of specifying its performance;
- 2.3.2. "Illumination axis (symbol I)" means a line segment from the reference centre to the light source.
- 2.3.3. "Observation axis (symbol O)" means a line segment from the reference centre to the photometer head;

- 2.3.4. "Observation angle (symbol α)" means the angle between the illumination axis and the observation axis. The observation angle is always positive and, in the case of retro-reflection, is restricted to small angles;
- 2.3.5. "Observation on half-plane" means the half-plane which originates on the illumination axis and which contains the observation axis;
- 2.3.6. "Reference axis (symbol R)" means a designated line segment originating on the reference centre which is used to describe the angular position of the retro-reflective device;
- 2.3.7. "Entrance angle (symbol β)" means the angle from the illumination axis to the reference axis. The entrance angle is usually not larger than 90° but, for completeness, its full range is defined as $0^\circ < \beta < 180^\circ$. In order to specify the orientation in full, this angle is characterised by two components, β_1 and β_2 ;
- 2.3.8. "Rotation angle (symbol ϵ)" means the angle indicating the orientation of the retro-reflecting material by an appropriate symbol with respect to rotation about the reference axis;
- 2.3.9. "First axis (symbol 1)" means an axis through the reference centre and perpendicular to the observation half-plane;
- 2.3.10. "First component of the entrance angle (symbol β_1)" means the angle from the illumination axis to the plane containing the reference axis and the first axis; range: $-180^\circ < \beta_1 < 180^\circ$;
- 2.3.11. "Second component of the entrance angle (symbol β_2)" means the angle from the plane containing the observation half-plane to the reference axis; range $-90^\circ < \beta_2 < 90^\circ$;
- 2.3.12. "Second axis (symbol 2)" means an axis through the reference centre and perpendicular to both the first axis and the reference axis. The positive direction of the second axis lies in the observation half-plane when $-90^\circ < \beta_1 < 90^\circ$ as shown in annex 1, figure 1.

2.4. Definition of photometric terms

- 2.4.1. "Coefficient of retro-reflection (symbol R')" means the quotient of the coefficient of luminous intensity R of a plane retro-reflecting surface and its area A

$$\left(R' = \frac{R}{A} \right. \quad \text{The coefficient of retro-reflection } R' \text{ is expressed} \\ \left. \quad \quad \quad \text{in candelas per m}^2 \text{ per lx (cd.m}^{-2}\text{.lx}^{-1}) \right)$$

$$\left(R' = \frac{I}{E_1 \cdot A} \right) \quad (\text{Luminance / Illumination});$$

2.4.2. "Angular diameter of the retro-reflector sample (symbol η_1)" means the angle subtended by the greatest dimension of the retro-reflective sample, either at the centre of the source of illumination or at the centre of the receiver ($\beta_1 = \beta_2 = 0^\circ$);

2.4.3. "Angular diameter of the receiver (symbol η_2)" means the angle subtended by the greatest dimension of the receiver as seen from the reference centre ($\beta_1 = \beta_2 = 0^\circ$);

2.4.4. "Luminance factor (symbol β)" means the ratio of the luminance of the body to the luminance of a perfect diffuser under identical conditions of illumination and observation.

2.5. Description of Goniometer

A goniometer which can be used in making retro-reflection measurements in the CIE geometry is illustrated in annex 1, figure 2. In this illustration, the photometer head (O) is arbitrarily shown to be vertically above the source (I). The first axis is shown to be fixed and horizontal and is situated perpendicular to the observation half-plane. Any arrangement of the components which is equivalent to the one shown can be used.

2.6. Definition of "type"

Marking materials of the different types means materials which differ in such essential respects as:

2.6.1. The trade name or trade mark;

2.6.2. The characteristics of the retro-reflective material;

2.6.3. The parts affecting the properties of the retro-reflective materials or devices.

3. APPLICATION FOR APPROVAL

3.1. The application for approval of a retro-reflective marking material shall be submitted by the holder of the trade name or trade mark, or if necessary by his duly accredited representative, and shall be accompanied by:

3.1.1. Drawings, in triplicate, sufficiently detailed to permit identification of the type. The drawings shall show geometrically the orientation in which the marking materials are to be fitted to a vehicle. They shall also show the position intended for the approval number and the identification symbol in relation to the circle of the approval mark;

3.1.2. A brief description giving the technical specifications of the retro-reflective marking materials;

3.1.3. Samples of the retro-reflective marking materials, as specified in annex 4;

4. TRADE NAMES AND OTHER MARKS

4.1. Every marking material submitted for approval shall bear:

4.1.1. The trade name or trade mark of the applicant;

4.1.2. An orientation mark "TOP" which must be inscribed on any marking material whose retro-reflective system is not omnirotational at least

on strips in a 0.5 m distance,
on areas within 100 x 100 mm².

4.2. The marks shall be clearly legible on the outside of the marking material and shall be indelible.

5. APPROVAL

5.1. If the retro-reflective marking material submitted for approval in accordance with paragraph 4 above meets the requirements of this Regulation, approval for this type of marking material shall be granted.

5.2. An approval number shall be assigned to each type approved. Its first two digits (at present 00 for the Regulation in its original form) shall indicate the series of amendments incorporating the most recent major technical amendments made to the Regulation at the time of issue of the approval. The same Contracting Party may not assign the same number to another type of retro-reflective marking material.

5.3. Notice of approval or refusal or extension of approval of a type of marking material under this Regulation shall be communicated to the Parties to the 1958 Agreement which apply this Regulation by means of a communication form conforming to the model in annex 2 to this Regulation.

5.4. Every marking material conforming to a type approved under this Regulation shall bear, in addition to the marks prescribed in paragraph 4.1., a clearly legible and indelible international approval mark consisting of:

- 5.4.1. A circle surrounding the letter "E" followed by the distinguishing number of the country which has granted approval. 1/
- 5.4.2. The number of this Regulation, followed by the letter "R", a dash and the approval number according to paragraph 5.2.
- 5.4.3. The following additional symbols indicating the class of material:
- 5.4.3.1. "C" for material for contour/strip marking;
- 5.4.3.2. "D" for material for distinctive markings/graphics intended for a limited area;
- 5.4.3.3. "E" for material for distinctive markings/graphics for extended area.
- 5.5. The approval mark shall be visible and clearly legible on the outside of the marking material and shall be indelible and positioned at least once
- at 0.5 m intervals on strips,
on areas within 100 x 100 mm².
- 5.6. Annex 3 to this Regulation gives an example of the arrangement of the approval mark.
6. GENERAL SPECIFICATIONS
- 6.1. Retro-reflective marking materials shall be that way constructed that they function satisfactorily and will continue to do so in normal use. In addition, they shall not have any defect in design or manufacture that is detrimental to their efficient operation or to their maintenance in good condition.
- 6.2. Retro-reflective marking materials or parts thereof shall not be capable of being easily dismantled.

1/ 1 for Germany, 2 for France, 3 for Italy, 4 for the Netherlands, 5 for Sweden, 6 for Belgium, 7 for Hungary, 8 for the Czech Republic, 9 for Spain, 10 for Yugoslavia, 11 for the United Kingdom, 12 for Austria, 13 for Luxembourg, 14 for Switzerland, 15 (vacant), 16 for Norway, 17 for Finland, 18 for Denmark, 19 for Romania, 20 for Poland, 21 for Portugal, 22 for the Russian Federation, 23 for Greece, 24 (vacant), 25 for Croatia, 26 for Slovenia, 27 for Slovakia, 28 for Belarus, 29 for Estonia, 30-36 (vacant) and 37 for Turkey. Subsequent numbers shall be assigned to other countries in the chronological order in which they ratify or accede to the Agreement concerning the Recognition of Approval for Motor Vehicle Equipment and Parts, and the numbers thus assigned shall be communicated by the Secretary-General of the United Nations to the Contracting Parties to the Agreement.

- 6.3. The means of attachment of the marking materials shall be durable and stable.
- 6.4. The outer surface of the retro-reflective marking materials shall be easy to be cleaned. The surface shall therefore not be rough and any protuberances they may exhibit shall not prevent easy cleaning.
7. SPECIAL SPECIFICATIONS
- 7.1. Retro-reflective marking materials shall also satisfy the conditions as to shape and dimensions, and the colorimetric, photometric, physical and mechanical requirements set forth in annexes 5 to 8 to this Regulation.
- 7.2. Advertising, consisting of retro-reflective logos, distinctive markings or letters/characters has to be decent. 2/
- 7.2.1. For class "D" marking materials the maximum values of the coefficient of retro-reflection are less or equal to the value defined in annex 7, table 2, and are intended to be used in distinctive markings, graphics.
- 7.2.2. For class "E" marking materials the maximum values of the coefficient of retro-reflection are less or equal to 33 per cent of the values defined in annex 7, table 2.
- 7.3. Depending on the nature of retro-reflective marking material, the competent authorities may authorize laboratories to omit certain unnecessary tests, provided that such omission is mentioned under "Remarks" on the form notifying approval.
8. MODIFICATIONS AND EXTENSION OF APPROVAL FOR RETRO-REFLECTIVE MARKING MATERIALS
- 8.1. Every modification of the retro-reflective marking material shall be notified to the administrative department which granted the type approval. The department may then:
- 8.1.1. either consider that the modifications made are unlikely to have appreciable adverse effects and that in any case the type of device still complies with the requirements;
- 8.1.2. or require a further test report from the technical service responsible for conducting the tests.

2/ Nothing in this Regulation shall preclude the national authorities to prohibit the use of retro-reflective advertising, logos, distinctive markings, letters/characters as defined in paragraph 2.1.3. of this Regulation.

8.2. Confirmation or refusal of approval, specifying the alterations, shall be notified by the procedure specified in paragraph 5.3. above to the parties to the Agreement applying this Regulation.

8.3. The competent authority issuing the extension of approval shall assign a series number to each communication form drawn up for such an extension.

9. CONFORMITY OF PRODUCTION

The conformity of production procedures shall comply with those set out in the Agreement, appendix 2 (E/ECE/324-E/ECE/TRANS/505/Rev.2), with the following requirements:

9.1. Any retro-reflective marking material approved to this Regulation shall be so manufactured as to conform to the type approved by meeting the requirements set forth in paragraphs 6 and 7 above.

9.2. The conformity of production shall not be contested if the mean value of the photometric measurements of five specimens taken at random deviates unfavourably by not more than 20 per cent from the prescribed values given in annex 7 of this Regulation.

9.3. The conformity of production shall not be contested, if the mean value of the colorimetric properties of five specimens taken at random meet the specifications of annex 6 of this Regulation, to be judged by visual inspection.

9.4. The authority which has granted type approval may at any time verify the conformity control methods applied in each production facility. The normal frequency of these verifications shall be once every two years.

10. PENALTIES FOR NON-CONFORMITY OF PRODUCTION

10.1. The approval granted in respect of a type of retro-reflective marking material pursuant to this Regulation may be withdrawn if the requirements set forth above are not met or if a retro-reflective marking material bearing the approval mark does not conform to the type approved.

10.2. If a Contracting Party to the Agreement applying this Regulation withdraws an approval it has previously granted, it shall forthwith so notify the other Contracting Parties applying this Regulation, by means of a communication form conforming to the model in annex 2 to this Regulation.

11. PRODUCTION DEFINITELY DISCONTINUED

If the holder of an approval completely ceases to manufacture a retro-reflective marking material approved in accordance with this Regulation, he shall so inform the authority which granted the approval. Upon receiving the relevant communication, that authority shall inform the other parties applying this Regulation by means of a communication form conforming to the model in annex 2 to this Regulation.

12. NAMES AND ADDRESSES OF TECHNICAL SERVICES RESPONSIBLE FOR CONDUCTING APPROVAL TESTS AND OF ADMINISTRATIVE DEPARTMENTS

The Contracting Parties to the Agreement applying this Regulation shall communicate to the United Nations Secretariat the names and addresses of the technical services responsible for conducting approval tests and of the administrative departments which grant approval and to which forms certifying approval or extension or refusal or withdrawal of approval, or production definitely discontinued issued in other countries, are to be sent.

Annex 1

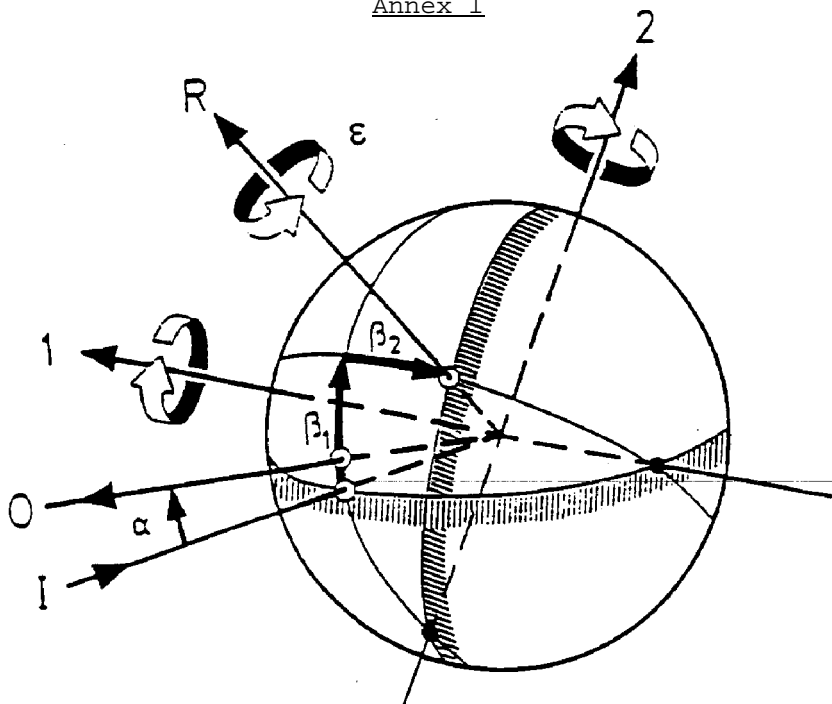

Figure 1

THE CIE CO-ORDINATE SYSTEM

- | | | |
|----------------|----------------------|--------------------------------------|
| 1: First Axis | I: Illumination Axis | α : Observation angle |
| 2: Second Axis | O: Observation Axis | β_1, β_2 : Entrance angles |
| | R: Reference Axis | ϵ : Rotation angle |

The CIE angular system for specifying and measuring retro-reflective marking materials. The first axis is perpendicular to the plane containing the observation axis and the illumination axis. The second axis is perpendicular both to the first axis and to the reference axis. All axes, angles, and directions of rotation are shown positive.

- Notes:
- (a) The principle fixed axis is the illumination axis.
 - (b) The first axis is fixed perpendicular to the plane containing the observation and illumination axis.
 - (c) The reference axis is fixed in the retro-reflective material and moveable with β_1 and β_2 .

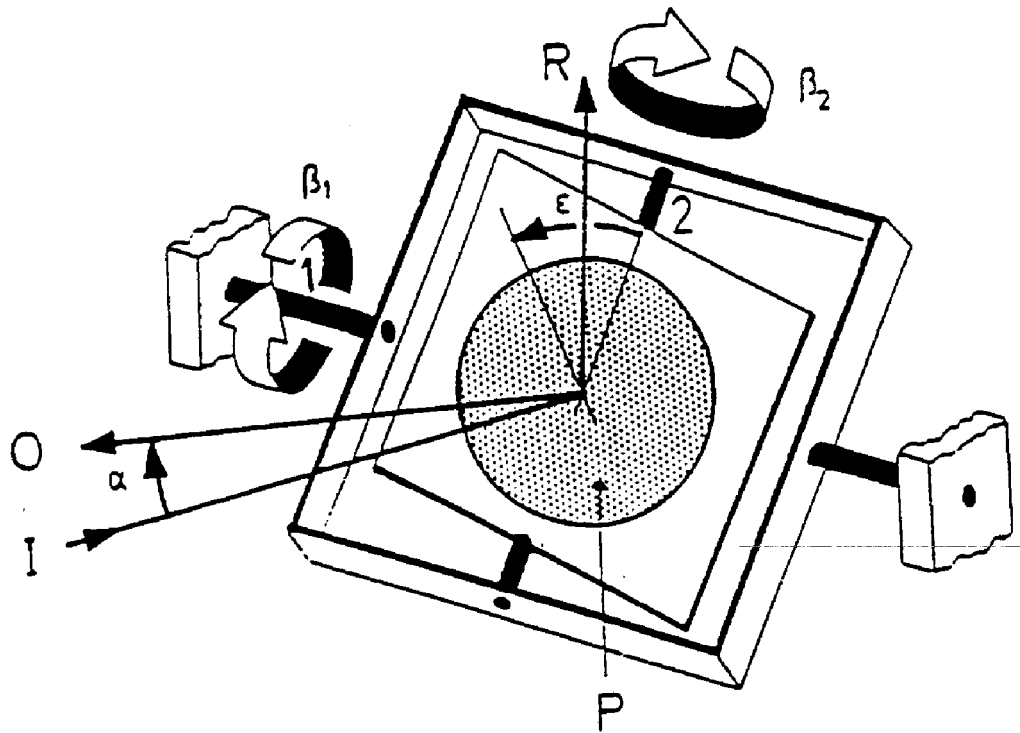

Figure 2

GONIOMETER MECHANISM EMBODYING THE CIE ANGULAR SYSTEM

- | | | |
|----------------|------------------------------|--------------------------------------|
| 1: First Axis | I: Illumination Axis | α : Observation angle |
| 2: Second Axis | O: Observation Axis | β_1, β_2 : Entrance angles |
| | R: Reference Axis | ϵ : Rotation angle |
| | P: Retro-reflective material | |

Representation of a Goniometer mechanism embodying the CIE angular system for specifying and measuring retro-reflective materials. All angles and directions of rotation are shown positive.

Annex 2

COMMUNICATION

(maximum format: A4 (210 x 297 mm))

issued by: Name of administration:
.....
.....
.....

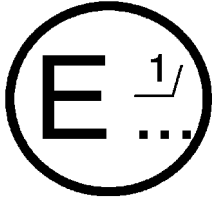

concerning: 2/ APPROVAL GRANTED
APPROVAL EXTENDED
APPROVAL REFUSED
APPROVAL WITHDRAWN
PRODUCTION DEFINITELY DISCONTINUED

of retro-reflective markings of heavy and long vehicles and their trailers,
pursuant to Regulation No. 104

Approval No: Extension No:.....

1. Trade name mark of the marking material:
2. Class of the marking material: C/D/E 2/
3. Name and address of the manufacturer:
4. If applicable, name and address of manufacturer's representative: ..
.....
5. Date on which the marking material was submitted for approval tests: .
6. Technical service responsible for carrying out the approval test: . . .
7. Date of test report issued by the technical service:
8. Number of test report issued by the technical service:
9. Remarks:
10. Approval granted/refused/extended/withdrawn 2/
11. Reason(s) for the extension (if applicable):

- 12. Place:
- 13. Date:
- 14. Signature:
Name:
- 15. Annexed is a list of documents making up the approval file, deposited with the competent authority which granted approval; a copy can be obtained on request.

- 1/ Name of the administration.
- 2/ Strike out what does not apply.

Annex 3

ARRANGEMENT OF THE APPROVAL MARK

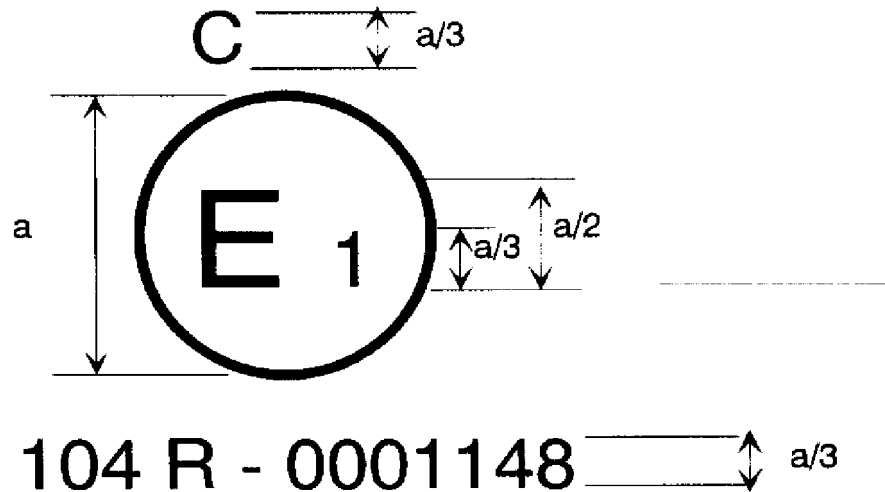

a = 12 mm min.

The retro-reflective marking material bearing the above approval mark has been approved in Germany (E1) under approval number 0001148. The first two digits of the approval number indicate that the approval was granted in accordance with the requirements of Regulation No. 104 in its original form. Symbol "C" indicates the class of the retro-reflective material which is intended for contour/strip marking. Symbol "D" shall indicate material for distinctive markings/graphics intended for a limited area and symbol "E" material for distinctive markings/graphics for extended area.

Note: The approval number and the additional symbol must be placed close to the circle and either above or below the letter "E" or to the left or right of that letter. The digits of the approval number must be on the same side of the letter "E" and face in the same direction. The approval number and the additional symbol must be placed diametrically opposite one another. The use of Roman numerals as approval numbers should be avoided so as to prevent any confusion with other symbols.

Annex 4

TEST PROCEDURE

TEST SAMPLES

1. Five test samples representing either strips or planes of retro-reflective marking materials have to be submitted to the test laboratory. In the case of strips, at least a length of 3 meters shall be provided; in the case of planes, at least a surface of 500 x 500 mm² shall be provided.
2. The test samples shall be representative of current production, manufactured in accordance with the recommendation of the manufacturer(s) of the retro-reflective marking materials. 1/
3. After verification of the general specifications (paragraph 6 of the Regulation) and the specifications of shape and dimensions (annex 5), the samples shall be subjected to the heat resistance test described in annex 8 to this Regulation, prior to the tests described in annexes 6 and 7.
4. The photometric and colorimetric measurements may be made on five samples. The mean values should be taken.
5. For other tests, samples which have not undergone any testing should be used.

1/ Test samples of retro-reflective marking materials shall be applied to edged and degreased aluminum panels of 2 mm thickness and shall be conditioned for 24 hours at 23°C ± 2°C at 50% ± 5% relative humidity prior to testing.

Annex 5

SPECIFICATION OF MARKING DIMENSIONS

1. SIDE AND REAR MARKING WITH STRIPS
 - 1.1. General

The markings shall be made of strips of retro-reflective material.
 - 1.2. Dimensions
 - 1.2.1. The width of a side and/or rear marking material shall be 50 mm +10/-0 mm.
 - 1.2.2. The minimum length of an element of a retro-reflective marking material shall be such that at least one approval mark is visible.

Annex 6

COLORIMETRIC SPECIFICATIONS

1. Retro-reflective marking materials shall be either white or yellow. Distinctive markings and/or graphics may be of any colour.
2. When measured with a spectrophotometer in accordance with the provisions of CIE document No. 15 (1971) and illuminated with the CIE Standard illuminant D65 at an angle of 45° to the normal and viewed along the normal (45°/0° geometry), the colour of the material in new condition shall be located within the area defined by the chromaticity coordinates in table 1 and comply with the luminance factor β .

Table 1 Chromaticity Co-ordinates						
Colour		1	2	3	4	Luminance factor β [1]
yellow	x [1]	0.545	0.487	0.427	0.465	≥ 0.16
	y [1]	0.454	0.423	0.483	0.534	
white	x [1]	0.300	0.385	0.345	0.260	≥ 0.25
	y [1]	0.270	0.355	0.395	0.310	

3. When illuminated by the CIE Standard illuminant A at entrance angle $\beta_1 = \beta_2 = 0^\circ$, or, if this produces a colourless surface reflection, angle $\beta_1 = 0^\circ$, $\beta_2 = + 5^\circ$, and measured at an observation angle of $\alpha = 20'$, the colour of the material in new condition shall be located within the area defined by the chromaticity coordinates in table 2.

Table 2 Chromaticity Co-ordinates					
Colour		1	2	3	4
yellow	x [1]	0.585	0.610	0.520	0.505
	y [1]	0.385	0.390	0.480	0.465
white	x [1]	0.373	0.417	0.450	0.548
	y [1]	0.402	0.359	0.513	0.414

Note: As the question of the night-time colours of retro-reflective marking materials is at present being studied by CIE TC 2.19, the above limits are therefore only provisional and will be revised later after CIE TC 2.19 has completed its work.

Annex 7

PHOTOMETRIC SPECIFICATIONS

1. When illuminated with a CIE Standard illuminant A and measured as recommended by CIE Publication No. 54, 1982, the coefficient of retro-reflection R' in candelas per m^2 per lux of the yellow or white retro-reflective areas in new condition shall be at least as indicated in table 1.
- 1.1. Minimum values for the coefficient of Retro-reflection
Photometric specifications for retro-reflective markings of Class C:

TABLE 1					
Minimum values for the Coefficient of Retro-reflection R' [$cd.m^{-2}.lx^{-1}$]					
Observation angle α [$^\circ$]	Entrance Angle β [$^\circ$]				
$\alpha = 0.33^\circ (20')$	β_1	0	0	0	0
	β_2	5	30	40	60
<u>Colour</u>					
yellow	300	130	75	10	
white	450	200	90	16	

- 1.2. Maximum values for the coefficient of retro-reflection
Photometric specifications for distinctive markings or graphics of
class D:

TABLE 2					
Maximum values for the Coefficient of Retro-reflection R' [cd.m ⁻² .lx ⁻¹]					
Observation angle α [°]	Entrance Angle β [°]				
$\alpha = 0.33^\circ (20')$	β_1	0	0	0	0
	β_2	5	30	40	60
Any colour		150	65	37	5

Note: If the sample is provided with an orientation mark, the specified values must only be observed for this orientation. Test samples without an orientation mark must be observed for values at 0° and 90° orientations as well.

Annex 8

RESISTANCE TO EXTERNAL AGENTS

1. Resistance to weathering

- 1.1. Procedure - For each test, two specimens of a sample unit (see paragraph 2.1.4. of this Regulation) are taken. One specimen shall be stored in a dark and dry container for subsequent use as "reference unexposed specimen".

The second specimen shall be subjected to a source of illumination in accordance with ISO Standard 105 - B02 - 1978, Section 4.3.1; the retro-reflective material shall be exposed until blue standard No. 7 has faded to No. 4 on the grey scale. After the test, the specimen shall be washed in a dilute neutral detergent solution, dried and examined for conformity with the requirements specified in paragraphs 1.2. to 1.4.

1.2. Visual appearance

No area of the exposed specimen shall show any evidence of cracking, scaling, splitting, blistering, delamination, distortion, chalking, staining or corrosion.

1.3. Colour fastness

The colour of the exposed specimen shall still meet the requirements in annex 6, tables 1 and 2.

1.4. Effect on the coefficient of retro-reflection of the retro-reflective material:

- 1.4.1. For this check, measurements shall be made only at an observation angle of $\alpha = 20'$ and an entrance angle of $\beta_2 = 5^\circ$ by the method given in annex 7.

- 1.4.2. The coefficient of retro-reflection of the exposed specimen when dry shall be not less than 80 % of the value in annex 7, tables 1 and 2.

2. Resistance to corrosion

- 2.1. A specimen of the sample unit shall be subjected to the action of a saline mist for 48 hours comprising two periods of exposure of 24 hours each, separated by an interval of 2 hours during which the specimen is allowed to dry.

The saline mist shall be produced by atomizing at a temperature of $35 \pm 2^\circ \text{C}$ a saline solution obtained by dissolving 5 parts by weight of sodium chloride in 95 parts of distilled water containing not more than 0.02 per cent of impurities.

- 2.2. Immediately after completion of the test, the sample shall show no sign of corrosion liable to impair the efficiency of the marking.
- 2.2.1. The coefficient of retro-reflection R' of the retro-reflective areas, when measured after a recovery period of 48 hours as specified in paragraph 1 of annex 7, at an entrance angle of $\beta_2 = 5^\circ$ and an observation angle of $\alpha = 20'$, shall be not less than the value in annex 7, table 1 or more than the value in table 2 respectively. Before measuring, the surface shall be cleaned to remove salt deposits from the saline mist.
3. Resistance to fuels
- A section of a sample unit not less than 300 mm long shall be immersed in a mixture of n-heptane and toluol, 70 per cent and 30 per cent by volume, for one minute.
After removal, the surface shall be wiped dry with a soft cloth and shall not show any visible change which would reduce its effective performance.
4. Resistance to heat
- 4.1. A section of a sample unit not less than 300 mm long shall be kept for 12 hours (in the case of moulded plastics reflectors this time shall be 48 hours) in a dry atmosphere at a temperature of $65 \pm 2^\circ\text{C}$ after which the sample shall be allowed to cool for 1 hour at $23 \pm 2^\circ\text{C}$. It shall then be kept for 12 hours at a temperature of $-20 \pm 2^\circ\text{C}$.
- 4.2. The sample shall be examined after a recovery time of 4 hours under normal laboratory conditions.
- 4.3. After this test, no cracking or appreciable distortion of the surface particularly of the optical units, shall be evident.
5. Resistance to cleaning
- A test sample smeared with a mixture of detergent lubricating oil and graphite shall be easily cleaned without damage to the retro-reflective material surfaces when wiped with a mild aliphatic solvent such as n-heptane, followed by washing with a neutral detergent.
6. Stability of photometric properties
- 6.1. The approval granting authority has the right to test the optical properties stability of a retro-reflecting material in use (when used for marking or as distinctive markings/graphics).
- 6.2. The administrative departments of Contracting Parties, in which the approval was granted, may undertake the same tests. If "systematic failures in use" occur for a type of retro-reflective material, the tested material samples shall be transferred for appraisal to the authority which granted approval.

- 6.3. If other criteria are missing, the notation "systematic failures in use" for a type of retro-reflective material is to be established according to paragraph 6 of this Regulation.
7. Resistance to penetration of water
- 7.1. Sample unit of retro-reflective marking shall be immersed for 10 minutes in water at a temperature of 50 ± 5 °C, the highest point of the upper part of the retro-reflective surface being 20 mm below the surface of the water. This test shall be repeated after turning the sample unit through 180° , so that the retro-reflecting surface is at the bottom and the rear face is covered by about 20 mm of water. The sample unit(s) shall then be immediately immersed in the same conditions in water at a temperature of 25 ± 5 °C.
- 7.2. No water must penetrate to the reflecting surface of the sample unit. If visual inspection clearly reveals the presence of water, the retro-reflective marking shall not be considered to have passed the test.
- 7.3. If visual inspection does not reveal the presence of water or in case of doubt, the coefficient of retro-reflection R' shall be measured in conformity with annex 7, the sample unit being first lightly shaken to remove excess water from the outside.
-

Annex 9

GUIDELINES FOR THE MARKING SHAPE AND MOUNTING REQUIREMENTS 1/

1. SIDE AND REAR MARKING WITH STRIPS

- 1.1. Retro-reflective marking materials installed on vehicles may be made up of an element or several elements preferably continuously, parallel or as close as possible parallel to the ground.

The same rule applies for tractors, semi-trailers and other vehicle combinations. A combination of vehicles and trailers marked and unmarked in the sense of this Regulation is discouraged.

- 1.2. The mounting of the markings should identify as close as possible the entire length and width of the vehicle. "Entire" means at least 80 per cent of the length and/or width.
- 1.3. In case of non-continuous strips the distance between single elements should be as small as possible and should not exceed 50 per cent of the shortest element length.
- 1.4. Retro-reflective marking materials shall have a minimum height above the ground of at least 250 mm and a maximum height of 1,500 mm. However, 2,100 mm may be accepted in cases where technical conditions forbid the compliance with the maximum value of 1,500 mm.

2. CONTOUR MARKING

- 2.1. The mounting of the contour markings should identify as close as possible the overall shape of the vehicle to the side and rear.
- 2.2. In case of non-continuous strips, the distance between single elements should be as small as possible and should not exceed 50 per cent of the shortest element length.
- 2.3. The lower part of the retro-reflective marking materials should have a minimum height above the ground of at least 250 mm and a maximum height of 1,500 mm

1/ Nothing in this annex shall preclude the national authorities to impose requirements differing from these guidelines.

3. DISTINCTIVE MARKINGS AND GRAPHICS (ADVERTISING)

3.1. Retro-reflective distinctive markings and/or graphics should only be placed within the contour marking on the side of a vehicle, provided they do not impair the effectiveness of the contour marking and the mandatory lighting and light-signalling devices. Compared to the contour marking, the distinctive markings and/or graphics should be decent as specified in paragraph 3.2. below.

3.2. The condition of "decent" is fulfilled if:

3.2.1. The number of the letters/characters is less than 15;

3.2.2. The height of the letters/characters is between 300 mm and 1,000 mm;

3.2.3. The whole retro-reflective area is not larger than 2.0 m²;

3.2.4. No long conceptions as e.g. addresses and phone numbers are used.

4. EXAMPLES OF RETRO-REFLECTIVE MARKINGS

Examples of retro-reflective markings are shown in appendices 1 and 2.

Annex 9 - Appendix 1

EXAMPLES OF RETRO-REFLECTIVE MARKINGS WITH STRIPS

Example A

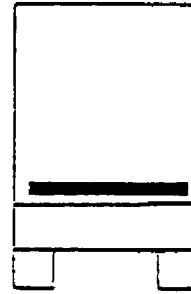
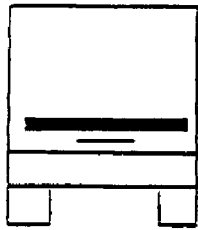
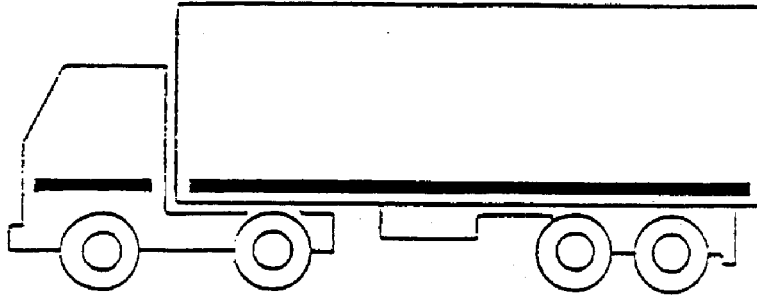

Exemple B

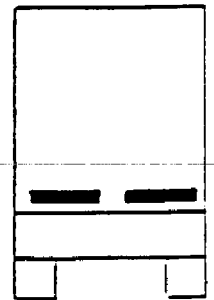
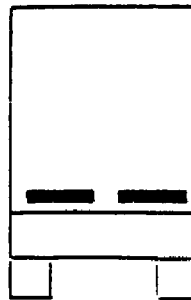
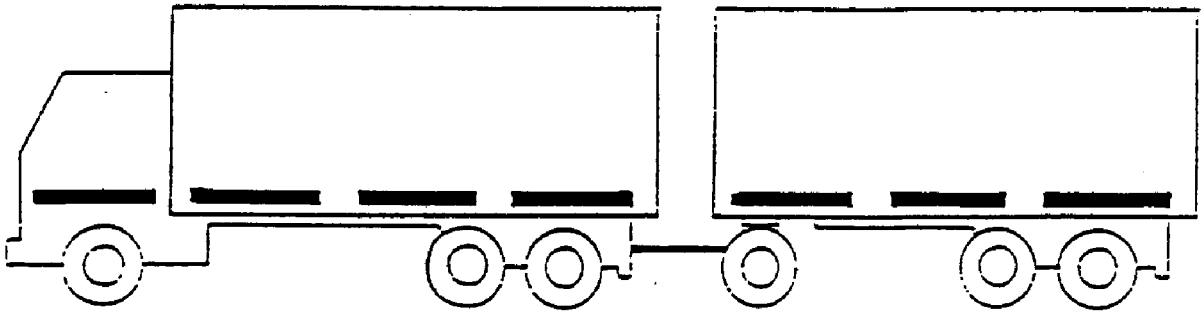

Annex 9 - Appendix 1 (cont'd)

EXAMPLES OF RETRO-REFLECTIVE MARKINGS WITH STRIPS

Example C

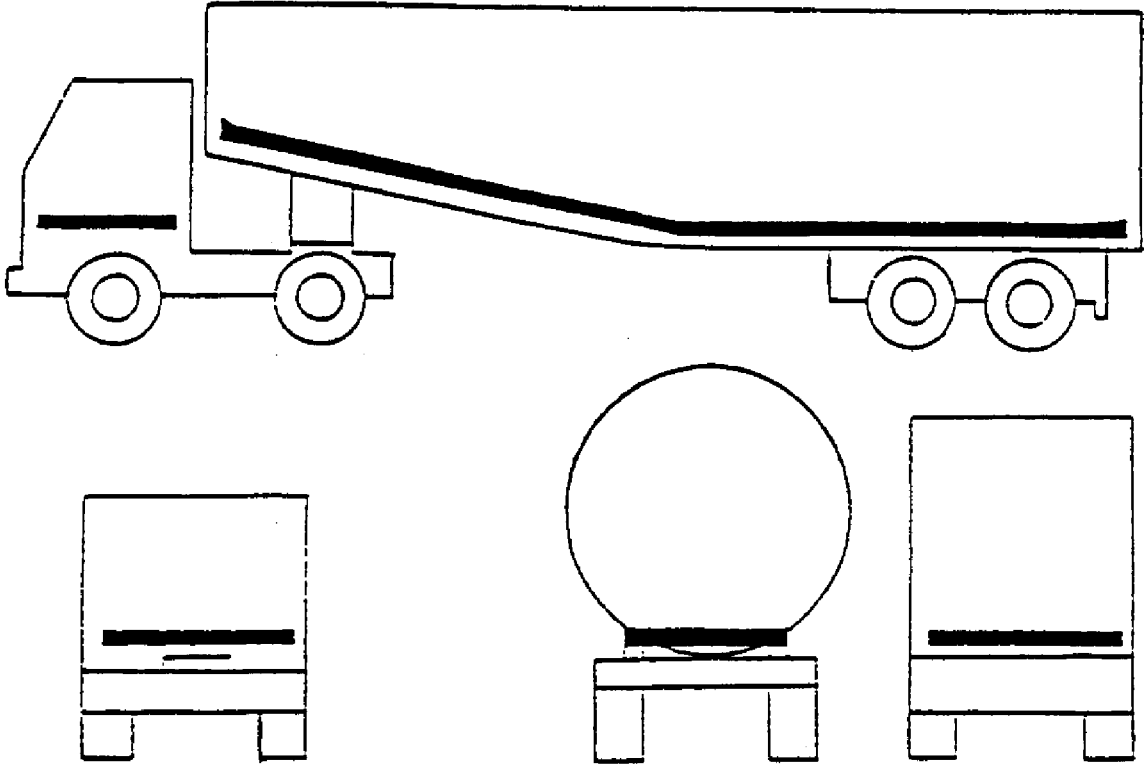

Exemple D

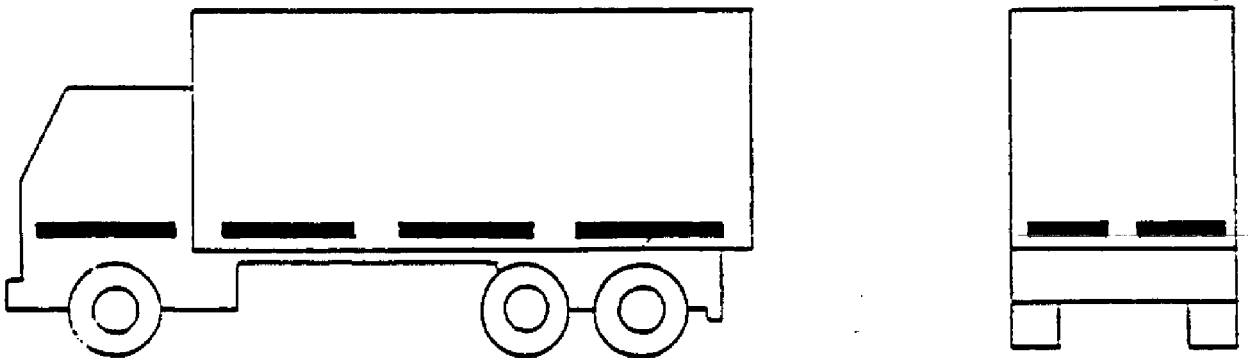

Annex 9 - Appendix 1 (cont'd)

EXAMPLES OF RETRO-REFLECTIVE MARKINGS WITH STRIPS

Example E

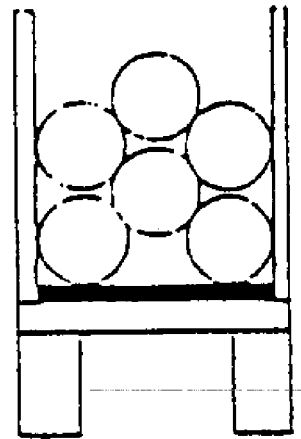
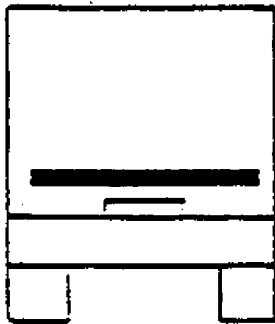
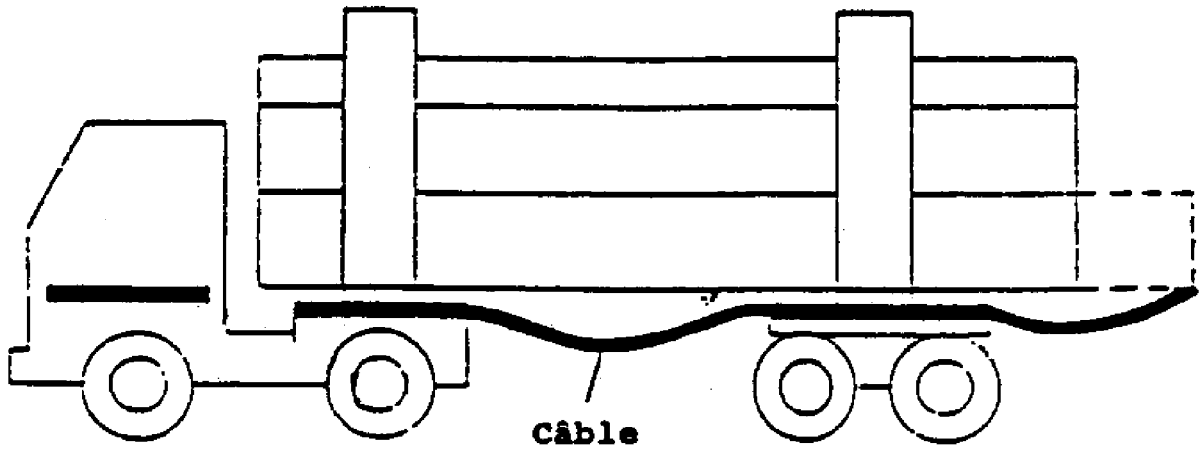

Annex 9 - Appendix 2

EXAMPLES OF RETRO-REFLECTIVE CONTOUR MARKINGS
(WITH DISTINCTIVE MARKINGS AND GRAPHICS)

Example A

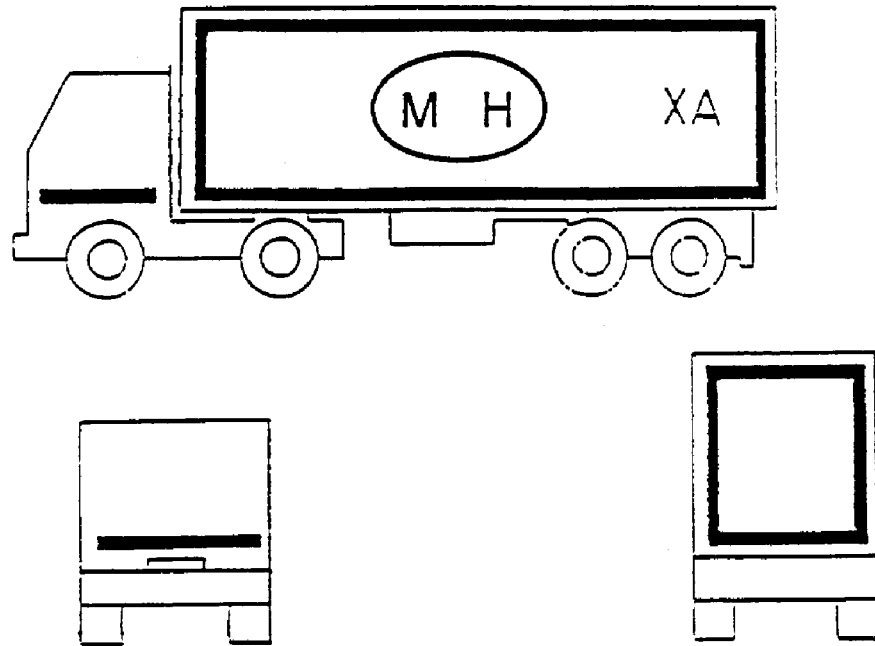

Example B

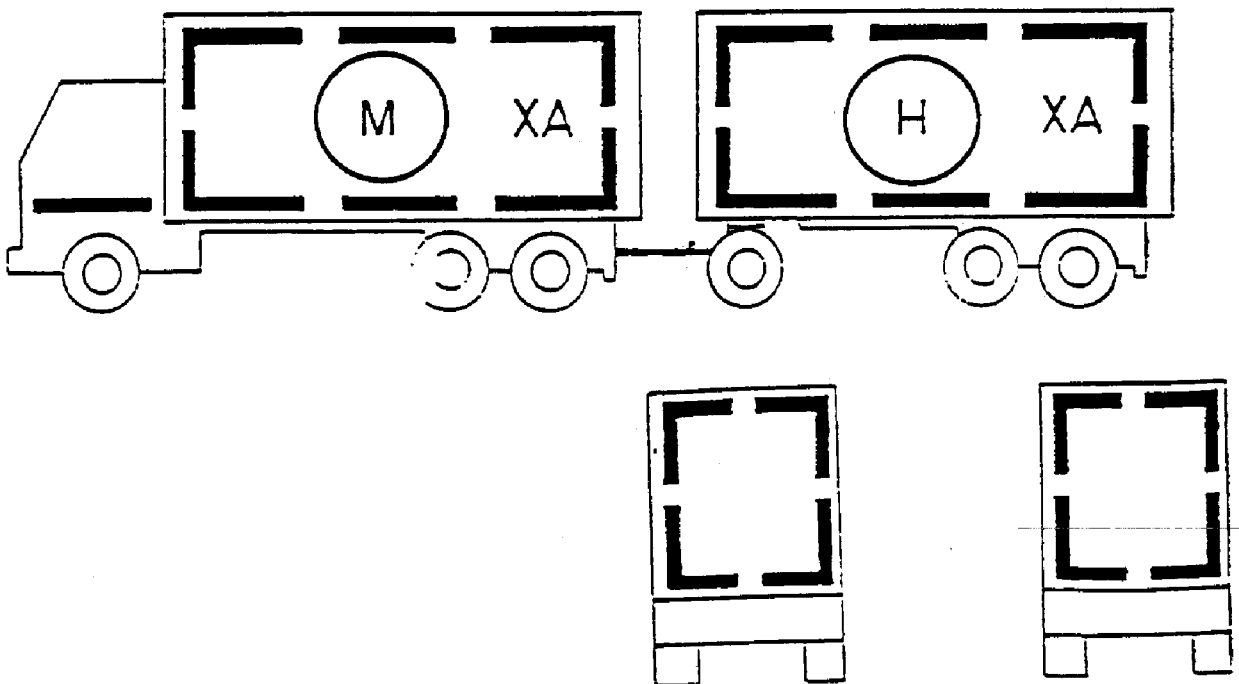

Annex 9 - Appendix 2 (cont'd)

EXAMPLES OF RETRO-REFLECTIVE CONTOUR MARKINGS
(WITH DISTINCTIVE MARKINGS AND GRAPHICS)

Example C

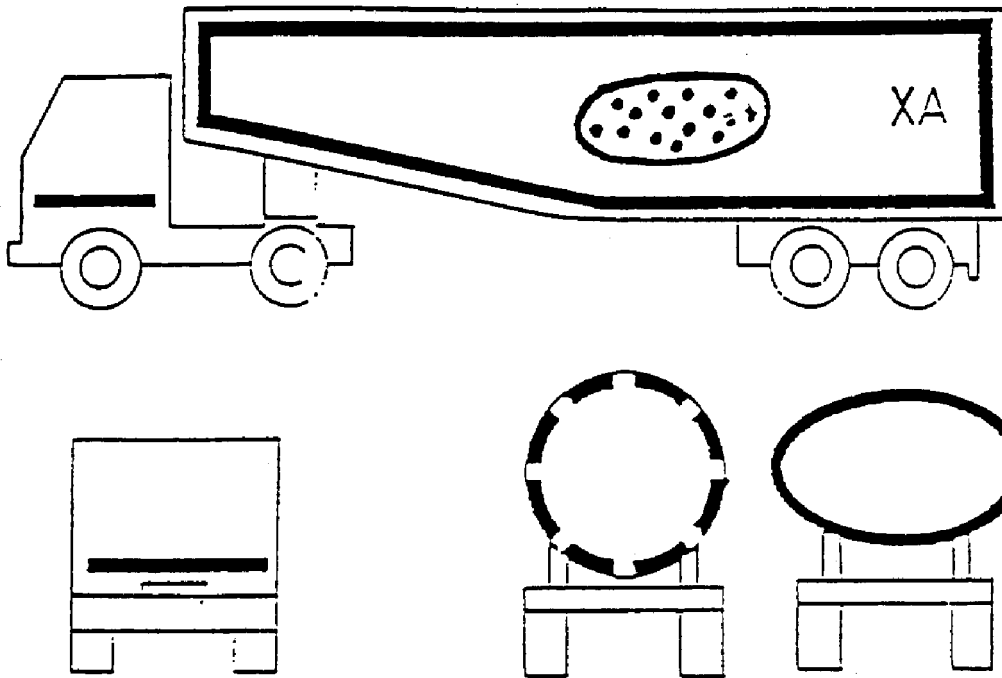

Exemple D

