

RSA



NATIONAL CAR TEST (NCT) MANUAL 2023

Passenger Vehicles (Up to 8 Passengers)

Údarás Um Shábháilteacht Ar Bhóithre
Road Safety Authority

Contents

INTRODUCTION	5
CORROSION ASSESSMENT	9
0. IDENTIFICATION OF THE VEHICLE.	13
1. BRAKING EQUIPMENT	19
2. STEERING	39
3. VISIBILITY	50
4. LAMPS, REFLECTORS AND ELECTRICAL EQUIPMENT	60
5. AXLES, WHEELS, TYRES AND SUSPENSION	87
6. CHASSIS, CAB AND BODYWORK	108
7. SAFETY RESTRAINTS, LOCKS, HORN, SPEEDOMETER, ESC, ECALL	127
8. NUISANCE.	137
GUIDELINES FOR COMPLETING MODIFICATIONS REPORTS	149
APPENDIX 1	155

Road Safety Authority

National Car Test (NCT) Manual

VERSION 5.1 (May 2023)

Application:

M1

(passenger vehicles up to 8 passengers)

These guidelines (also referred to as the “Manual”) are issued by the Road Safety Authority under the Road Traffic (National Car Test) Regulations 2017 No. 415 of 2017 (as amended), referred to herein as the “NCT regulations”. This Manual lays down the test method and pass/fail criteria to be adopted for the compulsory road-worthiness test of M1 vehicles.

The purpose of this Manual is to serve as a reference for those who carry out road-worthiness tests on vehicles with accommodation for up to eight passengers, including taxi and hackney cabs. Vehicle owners may also find the manual useful in that it details the inspections to which a vehicle will be subjected and the reasons why it may not be considered roadworthy.

This manual sets out the testing methods to be employed by those involved in national car testing. It also provides guidance to NCT test operators and testers in relation to the reasons why a vehicle may fail a road-worthiness test and the categorisation of defects.

The manual replaces the “National Car Test (NCT) Manual June 2021” in its entirety.

INTRODUCTION

1. DEFINITIONS

“**NCT**” means National Car Test.

“**Tester**” means a person employed under the NCT regime for the purpose of carrying out tests.

“**NCT Issuing Authority**” means a person authorised by the Road Safety Authority to conduct NCT tests and to issue test certificates.

“**NCT Test Centre**” means a premises authorised by the Road Safety Authority, at which NCT may be carried out.

The term Test means:

- an initial NCT test;
- a periodic NCT test;
- an initial or periodic re-test;

An **initial NCT test** is the first roadworthiness test of a vehicle and this test is due, in the majority of cases, from the fourth anniversary of the first registration of the vehicle or as otherwise specified in the NCT regulations.

A **periodic test** is a subsequent roadworthiness test following its initial test. Periodic tests are required to be carried out at a frequency as specified in the NCT regulations.

A **voluntary test** means a test carried out more than 90 days before a test due date.

A **re-test** means a test carried out on a vehicle, subsequent to the refusal of a test certificate in respect of that vehicle, where-

- (a) the application for the retest is made not more than 21 days after the day on which the test certificate was first refused, and
- (b) the test is carried out on a day which is not more than 30 days after the day on which a test certificate in respect of the vehicle was first refused.

In carrying out a re-test on a vehicle, only those items which gave rise to the refusal of the Test Certificate are to be tested. The items which failed must be re-tested as per the method of testing in the relevant section of the manual.

If during a retest the tester notices any other obvious defects, then the owner shall be notified and these additional items tested. Where a reason for failure is issued with respect to these additional test items, then this will be recorded on the test report.

The term “**owner**” in the context of applying for a test is taken to include the:

- the person by whom the vehicle is normally kept and
- in relation to a vehicle which is the subject of a hire- purchase agreement or lease, the person in possession of the vehicle under the agreement or lease.

“**Test report**” means the report issued by an issuing authority containing the result of the test in accordance with NCT Regulations.

“**Method of Testing**” details the ways in which the test of items on a vehicle are to be carried out and the equipment to be used. When carrying out each test, particular attention should be paid to the information given in the “Notes” since this gives guidance on the conduct and scope of the test.

“**Reasons for Failure**” gives direction on the type of defects which will result in the vehicle failing. A vehicle should only be assessed against the items and reasons for failure listed in this Manual and/or instructions issued by the Authority.

The methods of testing described in this Manual are intended to be carried out by trained and competent persons, working with appropriate supervision in suitable premises with safe equipment and tools.

“**Advisory Pass**” means, in relation to a vehicle, it is strongly recommended that the fault be repaired but a failed test will not result because of this fault alone.

“**Design Gross Vehicle Weight (DGWW)**” This is the weight of a vehicle including the maximum load it can carry in accordance with the manufacturer’s design specifications. It is also known as the Maximum Authorised Mass (MAM).

“**Individual design axle weight**” means the mass corresponding to the maximum permissible static vertical load transmitted to the ground by the wheels of the axle, on the basis of the construction features of the axle and of the vehicle and their design performances.

“**Manufacturer’s plate**” means a plate or label, affixed by the manufacturer on a vehicle that provides the main technical characteristics which are necessary for the identification of the vehicle and provides the competent authorities with the relevant information concerning the technically permissible maximum laden masses;

“**First registered**” means the date on which a vehicle was first registered, irrespective of country of registration, or where only the year of first registration is known, that year, in combination with the day and month of first registration in the State and “first registered” is to be read accordingly.

“Insecure”

The term “**insecure**” is used throughout this Manual to describe a defective condition. The term should be taken by testers to mean the following:

- (a). that a component on the vehicle has relative movement either at its fixing or in relation to an associated component where there should be none or
- (b). that a component is not safely or completely attached either at its fixing or to an associated component.

“Obviously Worn”

A component will be considered worn where the wear is to such an extent that it is either;

- (a). likely to fail, or
- (b). clearly not functioning effectively as designed, or
- (c). visibly worn beyond manufacturer’s known permitted limits, or
- (d). likely to affect the operation or condition of another safety related component.

2. SCOPE

This Manual applies to the following categories of vehicles;

Category M1: Vehicles designed and constructed for the carriage of passengers and comprising of no more than eight seats in addition to the driver’s seat.

3. MAKING A REQUEST FOR A NCT TEST BOOKING

A request for a NCT test booking must be made to the National Car Testing Service (NCTS) booking telephone line / in writing by post / email / fax or on line. Full details of how to make a request for a test booking can be found at www.ncts.ie.

4. PRESENTATION OF ID

A person who presents a vehicle to be tested must produce required identification i.e. a driving licence or public services card. Where the required identification is not produced at the time of the test, the test may be carried out and a test report issued. However, a Test Certificate will not be issued until such time as the required identification is produced at NCTS.

5. TEST REPORTS AND TEST CERTIFICATE

Before a vehicle that has been tested, leaves the Test Centre, a statement of result must be issued for that vehicle giving details of any failed items. Where the tester is satisfied that the vehicle has passed all the

required test items specified in this Manual, then a Test certificate is issued (apart from point 4 above) and or in the case of minor only defects. Where a Test certificate is not issued, the reasons for refusal will be provided to the owner in the test report.

6. DEFICIENCY CATEGORISATION

Deficiencies found during the test shall be categorised in accordance with Directive 2014/45/EU into one of the following groups:

Minor defects (MiD); having no significant effect on the safety of the vehicle or impact on the environment and other minor non-compliances. If only minor defects are identified, the vehicle will be deemed passed “Pending Re-Check”. The Test certificate will not issue until the vehicle is re-presented for a visual inspection with the deficiencies rectified.

Major defects (MaD); defects that may prejudice the safety of the vehicle, have an impact on the environment, put other road users at risk or other more significant non-compliances.

Dangerous defects (DD); defects constituting a direct and immediate risk to road safety or having an impact on the environment such that the vehicle should not be used on the road under any circumstances.

A tester shall be required to escalate the deficiency category, where any of the combinations of deficiencies set out at Appendix 1 of the NCT Manual are present. In addition, the tester may categorise a combination of deficiencies within the next most serious category, in the event of such combination of deficiencies not being set out expressly in the NCT Manual, where the tester is of the opinion that the combination of deficiencies results in a higher risk to road safety.

On completion of a test and where a vehicle is failed because of a Dangerous Defect, the tester should proceed as follows: The customer must be informed:

- Of the existence, extent and nature of the defect.
- That the owner and/or driver of a mechanically propelled vehicle, who drives a mechanically propelled vehicle in a public place while there is a defect affecting the vehicle which he knows of or could have discovered by the exercise of ordinary care and which is such that the vehicle is, when in motion, a danger to the public shall be guilty of an offence.
- That in the opinion of NCTS; the vehicle is dangerous.
- That the customer must make arrangements to have the vehicle removed from the test centre.

A sticker stating “Failed Dangerous” shall be attached to the vehicle.

The driver of the vehicle must be advised not to drive the vehicle if it has dangerous defects and be advised to have it towed away or otherwise carried away.

If the customer states that s/he is going to drive the vehicle:

- Advise that An Garda Síochána will be informed. If customer drives the vehicle off the premises the incident must be reported to An Garda Síochána immediately.

7. REASONS TO REFUSE TO CARRY OUT A NCT TEST

A NCT tester may refuse to carry out a test if in his or her opinion:

- any part of the vehicle or any of its equipment is
 - in such a dirty or dangerous condition as to make it unreasonably difficult to carry out the test, or
 - a load on the vehicle or other items are not adequately secured that it would be safe or practicable to carry out the test.
 - The test should be abandoned where a vehicle is presented in such a condition that the tester considers it unsafe to continue because it becomes apparent during the test that certain items cannot be satisfactorily inspected (e.g. dirty).
 - where the vehicle's engine does not comply with the preliminary check requirements¹.
 - where a Registration Book/Licence Certificate is not produced and the vehicle identification number does not correspond with the National Car Testing Service (NCTS) vehicle file.
 - where the Registration Book/Licence Certificate is produced and the vehicle identification number on the vehicle does not correspond with either the Registration Book/Licence Certificate or the NCTS vehicle file.
- fee payable in respect of NCT test has not been paid.

8. CIRCUMSTANCES IN WHICH TO REFUSE TO ISSUE A TEST CERTIFICATE

The circumstances in which the NCTS will refuse to issue a test certificate are as follows:

- Where the person who presents the vehicle to be tested fails to produce the required identification.

The owner and the Driver and Vehicle Computer Services Division must be notified where there are any discrepancies between the vehicle documentation or N.C.T.S. vehicle file and the vehicle in the Make, Model, Body type, EU Vehicle Category, VRT Vehicle Category, Motor Taxation Class or number of seats.

9. ODOMETER

The tester must record the odometer reading at the time of the test where an odometer is fitted and verify the reading using the OBD scan tool, where possible. When

the test report or Test certificate is being presented to the owner or the presenter of the vehicle, the tester shall point out the odometer reading. The owner or the presenter of the vehicle must verify that the odometer reading is correct, and if not shall immediately advise the Tester. The verification on the odometer reading must be completed before the vehicle departs from the NCT test centre as there will be no opportunity to change the reading at a later stage.

10. GENERAL

The purpose of this manual is to serve as a reference and guide for testers for those who carry out roadworthiness tests.

While testers are not expected to memorise all of the content in this manual, they should familiarise themselves with the method of testing and the reasons for failure to ensure testing is carried out to a consistently high standard utilising best practice.

The test is essentially a maintenance and condition check and shall be carried out using techniques and equipment currently available without the use of tools to dismantle or remove any part of the vehicle. A detailed assessment of a vehicle's design and construction is not part of the test. However, where the method of testing prescribed is a visual inspection and where this visual inspection is not sufficient to determine the condition of a component, the component should be further examined using one of the following methods:

- by using tools such as a mirror, tapping hammer, corrosion assessment tool or wire brush.
- by exerting force, with or without the aid of tools.

The above shall only apply where there is a clear doubt regarding the condition of a component. Panels (designed for easy removal) covering a component may be removed where it is possible to remove such panels without damaging the paintwork (e.g. attached with hand fasteners). Panels attached by means of pop rivets or other permanent fasteners should not be removed. It should also be noted that the test can only confirm the roadworthiness condition of the vehicle at the time of the test. It is not a prediction of future vehicle roadworthiness and should not be regarded as a warranty.

Since it is not practicable to lay down limits of wear and tolerance for all types of components of different models of vehicle, or to define acceptable amounts of damage deterioration and effectiveness; testers are expected to use their experience and judgment in making an assessment of the condition of components. The main criteria to be used when making a defect assessment are; has the component reached the stage where it is obviously likely to affect adversely the roadworthiness of the vehicle (dangerous) or where the condition of the component has clearly reached the stage at which replacement, repair or adjustment is necessary (major).

Where the vehicle manufacturer has provided wear tolerances these should be adhered to.

A tester must not under any circumstances issue a test certificate for a vehicle that is not tested in accordance with this Manual or that a Test certificate is conditional upon repairs or adjustments to the vehicle being made subsequent to the test. A tester shall conduct a thorough inspection of all of the test items strictly in accordance with this Manual.

The Road Safety Authority cannot accept responsibility for any injury to any person or any damage to any property arising from the conduct of any test described in this Manual. Nothing in this Manual may be construed as diminishing in any way the obligations on employers from health and safety regulatory acts in relation to the occupational health and safety at work of their employees.

It is the responsibility of the person presenting the vehicle for test to prove exemption from any requirement listed in this Manual.

11. ON-BOARD FUEL CONSUMPTION MONITORING (OBFCM)

In line with the requirements of EU Regulation 2019/631 and Commission Implementing Regulation (EU) 2021/392, from 20 May 2023, data related to On Board Fuel Consumption Monitoring (OBFCM) will be collected at NCT for vehicles first registered on or after 01 January 2021 that are equipped with on-board fuel and/or energy consumption monitoring devices. The data will be reported to the Environmental Protection Agency annually.

NOTES:

The Vehicle Identification Number on the vehicle must correspond with the information on the Vehicle Registration File/Book/Licence Certificate. Where difficulty is encountered in locating the Vehicle Identification Number it is the responsibility of the presenter to establish the location of this information on the vehicle.

Requirements¹ in regard to Modifications are outlined in the Manual.

Tyres should be inflated to the required pressure before a test is started otherwise test results may be misleading.

Where the brakes cannot be tested on a roller brake tester, due to the design of the vehicle, a road test must be carried out using a decelerometer to evaluate brake efficiency.

Corrosion Assessment

INTRODUCTION

When conducting a corrosion assessment for the purposes of the NCT Test, the following inspection and guidance procedures relating to corrosion should be applied in accordance with the methods prescribed within individual sections of this Manual. It is the responsibility of tester's to read and fully understand the guidance and procedures set out below before undertaking elements of the NCT Test related to corrosion assessment.

1. CORROSION

The effect of corrosion on the safety of the vehicle depends on its extent and the location where it has occurred.

A small amount of corrosion on an important part of the vehicle structure can make a vehicle unsafe where it destroys the continuity of the load bearing structure. On the other hand, heavy corrosion of unimportant sections may have no effect on the vehicle safety.

2. DETECTING CORROSION IN VEHICLES

Since advanced corrosion is almost always associated with an eruption of oxidised metal and pitting or bubbling of paint, a visual inspection is usually adequate to determine its presence. However, this method may not be adequate in all cases. In underbody areas prone to corrosion, such as steering and suspension mounting points and major structural components which include chassis, floor, structural sills and sub frames, the presence of corrosion should be checked using thumb pressure or by tapping with a hammer or other appropriate tools. Corrosion affected heavy gauge metal may be tapped harder than light gauge, but unwarranted force and damage must be avoided. In using this technique, care should be taken to avoid damage to panels or paint work not corrosion affected in any way. When checking for advanced corrosion, particular attention should be paid to seam welds and spot welds. These frequently corrode through from the interior and can result in the eventual detachment of panels. Any panel which is made insecure by such corrosion must be repaired even if it is an area of the component where corrosion holes are not an immediate danger. For the purposes of this Manual reference to "rust" should be interpreted as corrosion.

3. CLASSIFICATION OF CORROSION

The extent of corrosion can range from light surface corrosion to the total breakdown of parent metal.

In general, the formation of corrosion and resultant loss of metal occurs in areas which retain moisture, because of a build-up of road dirt and mud etc. The extent of corrosion is classified in three stages.

Stage 1 – Surface Corrosion

Light, powdery corrosion on the surface of a section of metal is termed surface corrosion.

Surface corrosion can occur on or behind any body panel, particularly if the protective coating is scratched or damaged.

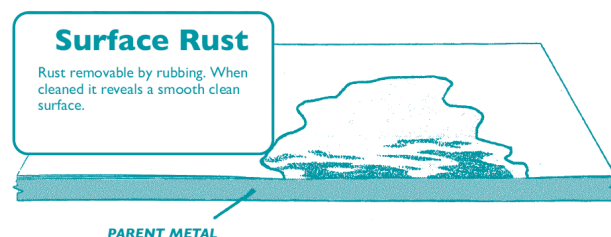

Stage 2 – Advanced Corrosion

Surface corrosion, if left unattended, will develop into an advanced form of corrosion which can usually be seen as an eruption of oxidised metal, either on bare metal or under paint. This eruption occurs because the corrosion reaction involves an increase in volume which causes pitting or bubbling of paint.

An example of a section affected by advanced corrosion is illustrated below.

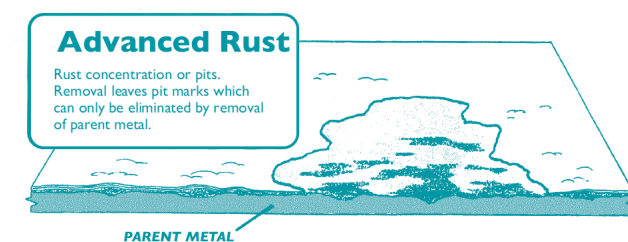

Stage 3 – Extensive Corrosion

The final stage of the corrosion process is the formation of a heavy encrustation of oxidised metal which completely replaces the parent metal. This results in a hole or series of holes in the body panel or structural member of the vehicle when the corrosion is removed. This category of corrosion can usually only be rectified by replacement of the affected body panels and parts. The illustration below shows a section affected by extensive corrosion.

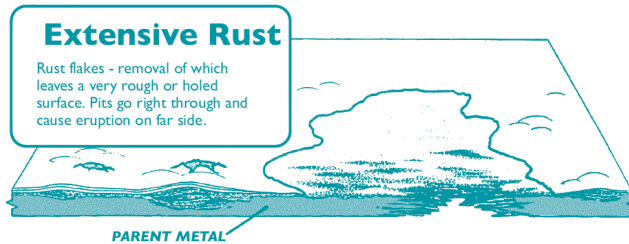

4. VEHICLE STRUCTURES

Vehicle structural components can be categorised according to their importance to safety.

PRIMARY STRUCTURE

The primary structure includes any structure or component which, if it collapsed, would render the vehicle uncontrollable or would considerably reduce occupant safety in a crash/collision situation. Only surface corrosion is acceptable in primary structure components. Any part of a load bearing member or load bearing panelling should be considered a reason for failure if it is weakened by corrosion to the extent that:

- By finger and thumb pressure it does not feel rigid, or
- It crumbles to leave a hole, or
- When tapped there is penetration, or it causes the metal to crumble or disintegrate.

TYPICAL PRIMARY STRUCTURE COMPONENTS

Certain areas of the vehicle structure are particularly important for the safety of a vehicle and particular attention must be paid to these areas during an inspection. These areas are:

- The load bearing parts/primary structure components of the vehicle which are depicted in the figures below.
- Any load bearing or supporting structure or supporting panelling within 30cm of the mounting location.

Figure 1. Primary Body Structure

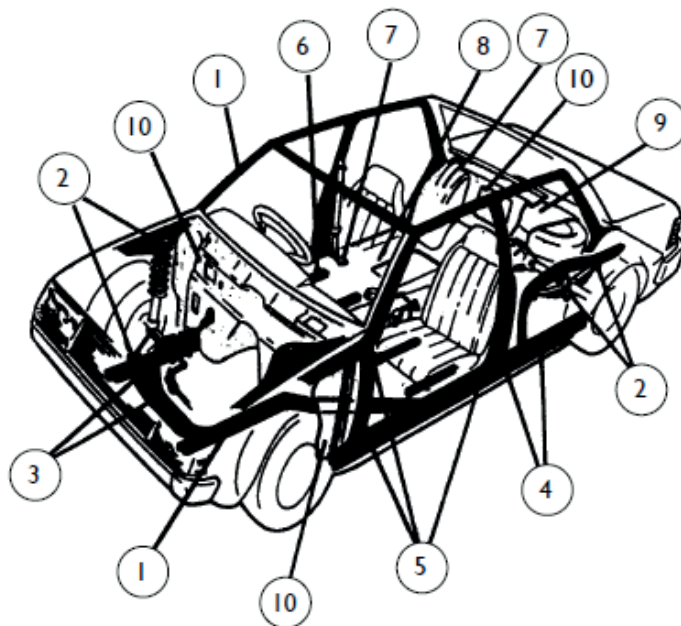

1. Main structural members such as subframes and chassis rails.
2. Suspension mountings and parts.
3. Steering component mounting points.
4. Door sills and pillars.
5. Door hinges and latch mounting points.
6. Seat anchorage points.
7. Seat belt anchorage points.
8. All floor panels.
9. Boot floor.
10. Bulkheads.

Figure 2. Secondary Body Structure

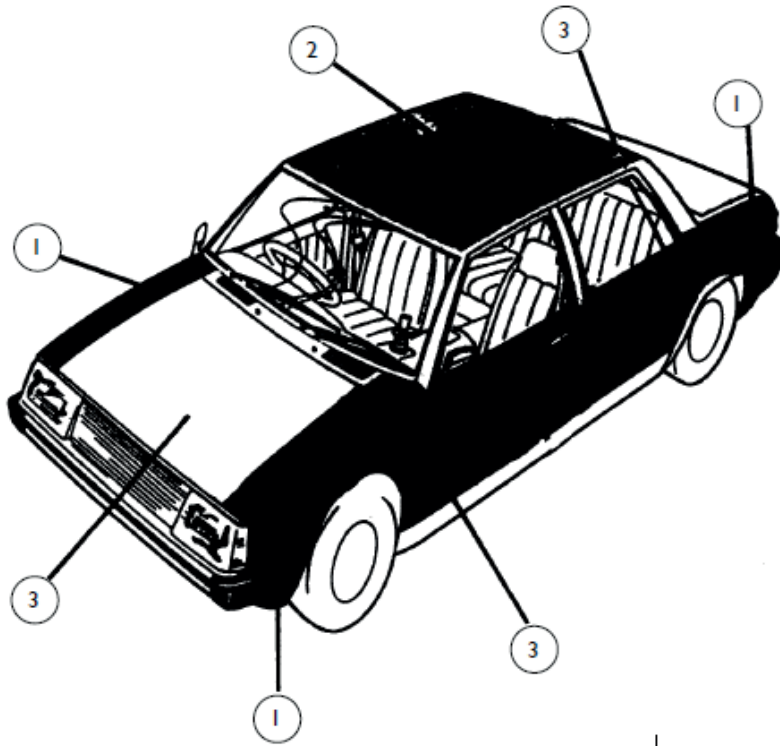

1. Wings or bumpers.
2. Roof.
3. Bootlid, bonnet and doors (areas within 100 mm of mounting and locking points are primary structures and must be free of advanced or extensive rust).

SECONDARY STRUCTURE

The second category includes any structure or component which, if it collapsed, would not immediately affect a vehicle’s controllability. Normally, surface corrosion or advanced corrosion in these structures or components would not make the vehicle unsafe. Extensive corrosion in these components is usually either hazardous to people in or near the vehicle because of its sharp edges or because exhaust fumes may enter the vehicle. In such cases, this type of corrosion would make the vehicle unsafe.

TYPICAL SECONDARY COMPONENTS

Extensive corrosion in these components can be hazardous to vehicle occupants and other road users.

1. Wings, bumpers or roof.
2. Boot lid, bonnet and doors (areas within 100mm of mounting and locking points are primary structures and must be free of advanced or extensive corrosion).
3. Exhaust system (vehicle may fail to meet noise emission standards if exhaust system is deteriorated due to corrosion).

CATEGORISING CORROSION

TYPE OF CORROSION	CATEGORY OF STRUCTURE	
	Primary	Secondary
Surface Corrosion	Acceptable	Acceptable
Advanced Corrosion	Not Acceptable	Acceptable*
Extensive Corrosion	Not Acceptable	Not Acceptable**

* Areas within 100 mm of hinges and locks (e.g. boot lid, bonnet and doors), are considered primary structures and must be free of advanced and extensive corrosion.

** Extensive corrosion is not acceptable in secondary components, if it renders the component hazardous to persons in or near the vehicle e.g. sharp edges, loose panels, or in the case of exhaust fumes, leakage of exhaust gases into the passenger compartment.

6. REPAIRS

Repairs made to primary structure components solely by using body filling compounds are not acceptable. Repairs should be made by completely welding in new metal of the same gauge as that of the manufactured component. However, plastic filler or fibreglass can be used to cosmetically smooth a non-structural component.

Extensive corrosion in structural members can only be repaired by replacing the affected member or by completely removing all corroded material and reinforcing it so that the original strength of the affected structural member is re-established.

0. IDENTIFICATION OF THE VEHICLE

CONTENTS

0.1. REGISTRATION PLATES14
0.2. VIN (CHASSIS NUMBER).16
0.5. MODIFICATIONS REPORT17

0. IDENTIFICATION OF THE VEHICLE

0.1. Registration Plates

0.1 REGISTRATION PLATES

Method of Testing

1. Check the registration number plates for security, location, format, legibility, visibility, correct colour and that the numbers are the same as that on NCTS. No other marks may appear on the plate. Any additional tabs, etc. outside the dimensions shown for the registration plate are not considered part of the plate.

Notes

- **Vehicles Registered on or after 1st January, 1987;** Letters and numbers must be black, set against a white background of reflex reflective material and minimum dimensions should be as shown in the sketches below.
- **Vehicles Registered prior to 1st January 1987, or vehicles bearing the registration index mark ZV;**
 - Reflex Reflecting Registration Plates; Front registration plates should have black numbers and letters on a white background. Rear registration plates should have black numbers and letters on a red or white background.
 - Non-Reflex Reflecting Registration Plates; Front and rear registration plates should have white, silver or light grey numbers and letters on a black background.
 - Back Lit Registration Numbers and Letters; where registration numbers and letters are back lit they should appear white in front and either white or red to the rear during lighting up hours. At all other times they should appear white on a black background.
- Owners of vehicles registered prior to 31st December, 1990, have the option of converting their registration plates to the new format.
- **Vehicles Registered on or after 1st January, 1991;** Letters and numbers must be black set against a white background of reflex reflective material. The flag of the European Union, the Nationality Symbol, IRL, and the Irish language name of the City/County of registration to be shown. Plate dimensions must be as shown in the sketches below.
- Where the indented space provided for the number plate is not sufficient to accommodate a standard size number plate, the registration plate and registration letters and numbers may be reduced in size relative to the space provided for the number plate.

CHECK ITEMS

REASONS FOR FAILURE

SEVERITY

Check for:

a. Presence and security.	(a). One or both plates missing, so insecure that they are likely to fall off.	MaD
b. Accuracy	(b). Numbers or letters missing, illegible or wrong size (see notes).	MaD
c. Correct format	(c). Numbers, letter or background of incorrect colour (see notes).	MaD
d. Illegal marks	(d). Marks, other than those prescribed, on the plate within the boundary shown in the diagram.	MaD
e. Compatibility with records	(e). Not in accordance with vehicle documents or records.	MaD
f. Obstruction and condition	(f). Number plate damaged, obstructed, faded, dirty, delaminated, deteriorated or obscured so that it is likely to be misread or is not easily legible.	MaD

0.1. Registration Plate – Example Plates

Either of the example plates below are acceptable. The addition of a tab containing other information is acceptable if all detail within the specification limits meets legislative requirements (S.I. No. 287 of 1990) and no other marks appear within this area (110mm x 520mm). The same criteria should be applied to 220mm x 340mm plates.

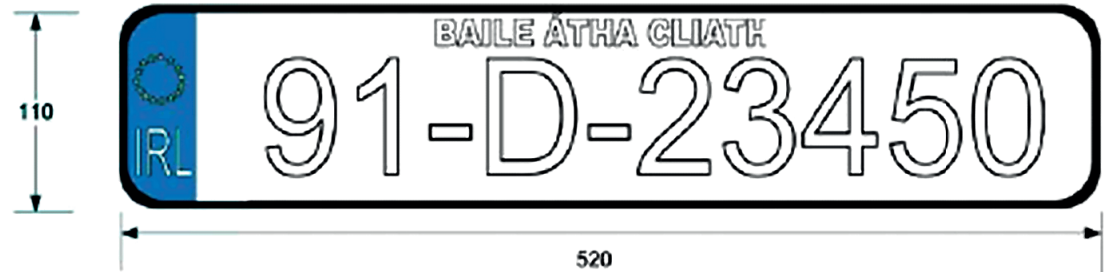

0.2. VIN (Chassis Number)

0.2. VIN (CHASSIS NUMBER)

Method of testing

1. Check that the VIN is indelibly marked on the chassis and fully corresponds to the number on NCTS for the vehicle. If not this is a reason for failure, except in the case where at a minimum the last six digits of the VIN on NCTS and the VIN indelibly marked on the chassis of the vehicle matches an Advisory Pass shall apply.
2. Check that the vehicle meets with the description and EU category assigned to it on NCTS.
3. Check that the VIN, indelibly marked on the chassis frame matches with the VIN recorded using the OBD scan tool. Where a difference is found, details shall be recorded on the vehicle inspection report.

Notes

- In the case where at a minimum the last six digits of the VIN on NCTS and the VIN indelibly marked on the chassis of the vehicle matches, in this case the tester may select an Advisory Pass for this test item, the NCT testing centre should still provide the customer with the correct VIN number in writing as marked on the chassis of the vehicle; on test centre headed paper using the revised template prepared by the RSA. The customer should be advised to get their vehicle registration certificate amended as per the template provided.
- Where a new VIN plate has been fitted (e.g. conversions/modifications), then the original VIN plate should be retained alongside the new VIN plate.
- **Advisory Pass applies where the VIN on the vehicle registration certificate does not exactly match the VIN indelibly marked on the vehicle chassis (but the last six digits of the VIN on the vehicle registration certificate and marked on the chassis match).**

CHECK ITEMS	REASONS FOR FAILURE	SEVERITY
Check for: a. Presence and condition. b. Legibility and falsification. c. Compatibility with vehicle documents.	(a). Missing or not legible on chassis/frame. (b). Incomplete, illegible, obviously falsified, or does not match the vehicle documents/NCTS data. (c). Illegible vehicle documents or clerical inaccuracies.	MaD MaD MiD

0.5. Modifications Report

0.5. MODIFICATIONS REPORT

Application

This section applies in respect of vehicles that have been modified since their last NCT Test in a manner that requires a modifications report as per the template in this Manual.

1. Check that the report has been presented in the acceptable form and is complete.
2. Check that the report corresponds with the modifications identified.

Application

1. The vehicle's owner (or the presenter on the owner's behalf) shall confirm whether any repairs or modifications have been carried out to a vehicle since its last NCT which may adversely affect the roadworthiness of one or more of the items to be tested (see Note 1).
2. In respect of vehicles modified since their last NCT, a modifications report must be provided in the following cases;
 - Chassis work, including lengthening/shortening the wheel base or the replacement of chassis rails (e.g. limousine conversion).
 - A vehicle which has been converted. This includes (but is not limited to the following):
 - M2 (mini bus) or N1 (light goods vehicle) converted to an M1 (passenger car).
 - Modification to the steering system (this includes power steering and steering wheel).
 - Modification to the suspension system (including modifications to anti-roll bars).
 - Modification to the braking system including the addition or removal of equipment.
 - Modifications to safety belts (including anchorages), air bags or the addition of seats and safety restraint systems.
 - Major modifications to the cab or body work.
 - Modifications or repairs which may adversely affect the roadworthiness of one or more of the items to be tested as part of the test including where "obviously unsafe repairs or modifications" is specified in this Manual as a reason for failure.
3. Where during the NCT, the tester notices a repair or modification which may adversely affect the roadworthiness of any of the test items including where unsafe "repairs or modifications" are specified in this Manual as a reason for failure, the tester shall seek a modifications report in writing substantially in the form outlined in this Manual. Where a historic report is provided, the tester shall determine whether this adequately addresses the issue and is in line with the form in this Manual and, if not, shall seek a new modifications report. As the NCT is essentially a maintenance and condition check, it is acknowledged that a tester will not be removing or dismantling any parts in the course of a normal roadworthiness test and that the finding of any modifications or repairs is based on a visual inspection of the vehicle only.
4. In the case of vehicles requiring a modifications report (as per 1, 2 or 3 above), this report shall be one issued by the vehicle manufacturer (or their authorised distributor), vehicle converter or by a Suitably Qualified Individual (see Note No.2). This report shall be on headed notepaper and must state;
 - Vehicle Make.
 - Vehicle Model and variant.
 - Description of body-type (not code) before and after modification (in the case of a modification). E.g. estate car to hearse.
 - Vehicle Registration Number.
 - VIN.
 - The purpose of the report.
 - The list of modifications or repairs made to the vehicle.
 - The standard of workmanship and specifications.
 - That the vehicle is safe to use on the road and that the modification/ repair does not diminish the technical status or integrity of the vehicle or other vehicle components and safety features.
 - That the vehicle meets with the Road Traffic (Construction, Equipment and Use of Vehicles) Regulations (as amended) and the Road Traffic (Lighting of Vehicles) Regulations as amended.
 - That the vehicle meets with the essential technical provisions of the EU Directives to which the modification relates for the year of manufacture and category of vehicle concerned.
5. A template for the modifications report required to be presented can be found in set out in the guidelines for completing modifications of this Manual.
6. A vehicle that has been converted from M2 or N1 to M1 since its last CVR test requires a letter on official headed paper from the manufacturer or their authorised distributor to accompany the modifications report to affirm the suitability of the type of modification which has been undertaken. This letter shall be uploaded by the tester.

0.5. MODIFICATIONS REPORT

(1) In accordance with the Road Traffic (Construction, Equipment and Use of Vehicles) Regulations, S.I. 190 No. of 1963 (as amended), all vehicles on public roads must conform with the general principles set down in these Regulations in relation to the condition and maintenance of vehicles. All parts and equipment of every vehicle shall be in good and efficient working order. It is each vehicle owner's responsibility to ensure his or her vehicle is in compliance with the law and maintained in a roadworthy condition at all times.

(2) A "Suitably Qualified Individual" (SQI) means a mechanical or automotive engineer, an automotive assessor or a person with similar qualifications who, by reason of his or her competence, experience and independence, is an appropriate person to assess the fitness and safety of a vehicle and who carries the appropriate indemnity relative to his or her position.

(3) A modifications report is not required where:

(a) a vehicle has been subject to a post registration modification approval scheme in another Member State prior to being registered in Ireland and documentation (approval report in English) is provided from the competent authority in the Member State concerned, giving details of the nature of the modifications carried out and the VIN of the vehicle.

However, where such documentation has been provided but does not correspond to modifications identified and which may adversely affect the roadworthiness of the vehicle then a modifications report for the relevant modifications shall be required.

(b) a vehicle has been type approved and has one of the following certificates of approval corresponding to the vehicle presented

- EC Certificate of Conformity (EC CoC) for a complete or completed vehicle
- National Small Series Type Approval Certificate of Conformity (Irish NSSTA CoC) for a complete or completed vehicle
- Individual Vehicle Approval Certificate (Irish IVA Certificate)

However, where such documentation has been provided but does not correspond to modifications identified and which may adversely affect the roadworthiness of the vehicle then a modifications report for the relevant modifications shall be required.

0.5. MODIFICATIONS REPORT

CHECK ITEMS	REASONS FOR FAILURE	SEVERITY
Check for:		
a. Presence and completeness.	(a). Not presented or incomplete.	MaD
b. Acceptable format.	(b). Not in the form (template acceptable by tester).	MaD
c. Compatibility with modifications.	(c). Does not correspond with modifications identified by tester.	MaD
d. Validity (expiry date).	(d). Not acceptable (e.g. report includes an expiry date).	MaD
e. Report presented where required.	(e). Modification report required.	MaD
f. Manufacturer approval (where necessary).	(f). Letter from manufacturer/ authorised distributor not presented where required (See notes above).	MaD
g. Report for repairs	(g). Modifications report required for repairs carried out.	MaD

1. BRAKING EQUIPMENT

CONTENTS

1.1. MECHANICAL CONDITION & OPERATION20
1.1.1. SERVICE BRAKE PEDAL / HAND LEVER PIVOT	20
1.1.2. PEDAL/HAND LEVER CONDITION AND OPERATION.	20
1.1.4. LOW PRESSURE WARNING GAUGE OR INDICATOR (WHERE FITTED)	21
1.1.6. PARKING BRAKE ACTIVATOR, LEVER CONTROL, PARKING BRAKE RATCHET, ELECTRONIC PARKING BRAKE	22
1.1.7. BRAKING VALVES (FOOT VALVES, UNLOADERS, GOVERNORS)	23
1.1.9. ENERGY STORAGE RESERVOIR PRESSURE TANK (WHERE FITTED)	23
1.1.10. BRAKE SERVO UNITS, VALVES, MASTER CYLINDER, (HYDRAULIC SYSTEMS)	24
1.1.11. RIGID BRAKE PIPES	25
1.1.12. FLEXIBLE BRAKE HOSES	26
1.1.13. BRAKE LININGS AND PADS	27
1.1.14. BRAKE DRUMS, BRAKE DISCS	28
1.1.15. BRAKE CABLES, RODS, LEVERS, LINKAGES.	29
1.1.16. BRAKE ACTUATORS (INCLUDING SPRING BRAKES / CALLIPERS / HYDRAULIC CYLINDERS).	30
1.1.17. LOAD SENSING VALVE	31
1.1.18. SLACK ADJUSTER AND INDICATORS	31
1.1.21. COMPLETE BRAKING SYSTEM	32
1.1.22. TEST CONNECTIONS (WHERE FITTED OR REQUIRED)	32
1.2. SERVICE BRAKING PERFORMANCE & EFFICIENCY (ROLLER BRAKE TEST)33
1.2.1. PERFORMANCE (IMBALANCE)	34
1.2.2. EFFICIENCY	34
1.4. PARKING BRAKE PERFORMANCE & EFFICIENCY.35
1.4.1. PERFORMANCE (IMBALANCE) & 1.4.2 (EFFICIENCY)	35
1.4.2. EFFICIENCY	35
1.6. ANTI-LOCK BRAKING SYSTEM (ABS)36
1.7. ELECTRONIC BRAKE SYSTEM (EBS).37
1.8. BRAKE FLUID38

1.1. Mechanical Condition & Operation

1.1.1. SERVICE BRAKE PEDAL / HAND LEVER PIVOT

Method of testing

- Check service brake pedal assembly/hand lever pivot for correct pivot operation/excessive side movement and that it releases correctly.

CHECK ITEMS	REASONS FOR FAILURE	SEVERITY
Check for: a. Operation (pivot). b. Wear (mounting/bush).	(a). Pivot too tight so its functionality is affected. (b). Excessive wear or play in mounting/bush.	MaD MaD

1.1.2. PEDAL/HAND LEVER CONDITION AND OPERATION

Method of testing

Check the pedal/hand lever for condition and operation by moving it from side to side and depressing it fully.

1. Check the fixing of the pedal pad to the pedal and the fixing of the pedal to the operating lever.
2. Depress the pedal to check for fouling on parts of the vehicle.
3. Release the handbrake, depress the pedal fully and check the position of the back of the pedal relative to the floor.
4. For hydraulic systems, fully depress the pedal and keep it depressed under a steady pressure. Note whether the pedal tends to creep down.
5. For hydraulic systems, release the parking brake and depress the pedal and note whether there is sponginess.
6. On some vehicles the action of the brakes is assisted by vacuum from the engine. Note whether this is operating satisfactorily by partially depressing the pedal, starting the engine and noting whether the pedal can be felt to dip.

Notes

- Hand lever in this section refers to the operation of the service brake by hand.
- Brake pedals that are not equipped with a pedal rubber should not be a reason for failure if they were not designed to have one.

CHECK ITEMS	REASONS FOR FAILURE	SEVERITY
Check: a. Operation (pedal travel). b. Condition (anti-slip provision). c. Operation (brake control). d. Condition & security (mounting). e. Creep or sponginess (hydraulic system). f. Pedal dip (vacuum system). g. Clearance (pedal and floor).	(a). Pedal travel is excessive, obstructed or insufficient reserve travel. (b). Service brake anti-slip provision is missing, loose, worn to the extent that it is no longer effective. (c). Brake control not releasing correctly. (d). Mounting is insecure, badly corroded or worn to the extent that the pedal can be moved from side to side. (e). In hydraulic systems, the pedal tends to creep down, or is felt to be spongy when held depressed. (f). In systems assisted by vacuum from engine, with pedal depressed and the engine started, no dip is felt in brake pedal. (g). Travel in the brake pedal indicates air in the brake system or brakes are in need of adjustment.	MaD MaD MaD MaD MaD MaD MaD

1.1.4. LOW PRESSURE WARNING GAUGE OR INDICATOR (WHERE FITTED)

Method of testing

1. Check that either a gauge or other visual or audible warning system is fitted. (This check is not necessary where effective braking is possible without the use of stored energy such as vacuum servo or compressed air assistance).
2. By repeated application of the foot-brake (service brake) pedal gradually exhaust the braking system of air or vacuum (with engine stopped).
3. If a gauge is fitted, note that the reading on the gauge falls steadily with each application of the brake and that when the gauge needle has reached the “warning mark” there is still enough vacuum (or air pressure) in the system to allow the brake to be applied at least four more times with vacuum (or air pressure) assistance.
4. If a warning lamp or audible or mechanical warning system is fitted, note that after this has operated there is still enough vacuum (or air pressure) in the system to allow the brake to be applied at least four more applications with vacuum (or air pressure) assistance.

Notes

- Where a vehicle is fitted with more than one warning system they must all be working.

CHECK ITEMS	REASONS FOR FAILURE	SEVERITY
Check for: a. Operation and malfunction. b. Functionality (visual/audible).	(a). Malfunctioning or defective gauge or indicator. (b). Low pressure warning gauge or indicator cannot be seen/ heard when air/vacuum is depleted.	MiD MaD

1.1.6. PARKING BRAKE ACTIVATOR, LEVER CONTROL, PARKING BRAKE RATCHET, ELECTRONIC PARKING BRAKE

Method of testing

The following inspections are to be completed from inside the vehicle.

Mechanical Parking Brake

1. Check the condition of the brake lever and its mounting with the brake lever in the 'off' position and note the amount of side play in the lever pivot by moving the lever from side to side.
2. Check the condition of the ratchet pawl mechanism pivots and safety guard.
3. Apply the brake slowly and check the effective operation of the pawl mechanism by listening for definite and regular clicks as the pawl moves over the ratchet teeth.
4. With the brake fully applied knock the top and each side of the lever and check that the lever is held in the 'on' position. Check that the lever is not at the end of its permitted travel and that there is no fouling of adjacent parts.

Electronic Parking Brake

5. Visually inspect the electronic parking brake controls while the braking system is operated.

Notes

- In some cases it is not possible to check these items completely from inside the vehicle, but only to obtain an indication of their condition. If a defect is suspected which cannot be verified from inside the vehicle, the inspection must be continued from a position underneath the vehicle.
- Check that the hub is not worn or damaged and that the hub spigot make sufficient contact with the wheel rim.
- Check where twin wheels are fitted that the spigots extend to the outer wheel.

CHECK ITEMS	REASONS FOR FAILURE	SEVERITY
Check:		
a. Presence, security and condition.	(a). Ratchet and pawl mechanism (where fitted) is missing, insecure, damaged or sticking, not holding correctly.	MaD
b. Wear (lever pivot or in ratchet mechanism).	(b). Wear at lever pivot or in ratchet mechanism.	MaD
c. Excessive wear (lever pivot or in ratchet mechanism).	(c). Excessive wear at lever pivot or in ratchet mechanism.	MaD
d. Operation ("on" position).	(d). Knocking the top or sides of the lever releases the brake.	MaD
e. Excessive movement/ impeded travel.	(e). Excessive movement of lever indicating incorrect adjustment or movement is obstructed.	MaD
f. Presence, damage and condition (electronic).	(f). Electronic park brake activator missing, damaged or inoperative.	MaD
g. Malfunction/ warning indicator.	(g). Malfunction indicator light not working, not going through the correct sequence or indicates any kind of failure of the system.	MaD
h. Presence, security, damage and condition (lever).	(h). Lever/lever mounting is missing, fractured, badly worn or corroded, insecure or mounting unsatisfactory.	MaD

1.1.7. BRAKING VALVES (FOOT VALVES, UNLOADERS, GOVERNORS)

Method of testing

1. Check for leaks, excessive discharge of oil and damage to valves or components while the braking system is applied.

CHECK ITEMS	REASONS FOR FAILURE	SEVERITY
Check for: a. Damage and leaks. b. Damage and excessive leaks (functionality affected). c. Oil discharge. d. Security and mounting. e. Hydraulic discharge/ leak. f. Excessive hydraulic discharge/ leak (functionality affected).	(a). Valve damaged or excessive air leak. (b). Valve damaged or excessive air leak that its functionality is affected. (c). Excessive oil discharge from compressor. (d). Valve insecure or inadequately mounted. (e). Hydraulic fluid discharge or leak. (f). Excessive hydraulic fluid discharge or leak(s) that its functionality is affected.	MaD DD MiD MaD MaD DD

1.1.9. ENERGY STORAGE RESERVOIR PRESSURE TANK (WHERE FITTED)

Method of testing

Visually inspect the energy storage reservoir pressure tank and carry out the following checks;

1. Check that the securing straps are free from cracks, fractures, excessive corrosion and do not chafe the reservoir or other fittings.
2. Check the reservoir for damage, corrosion and leaks.
3. With air pressure or vacuum built-up, check the drain device (where fitted) and for leaks in the system.

Notes

- Minor damage to reservoir should not be a reason for failure where the reservoir capacity is not unduly reduced by deformation. In cases where there is damage to a tank requiring the replacement / repair by welding of the tank 1.1.9 (b) below should apply.

CHECK ITEMS	REASONS FOR FAILURE	SEVERITY
Check: a. Damage and condition. b. Excessive damage or leaks. c. Drain device. d. Drain device operation. e. Security.	(a). Tank slightly damaged or slightly corroded. (b). Tank excessively damaged, corroded or leaking. (c). Drain device operation affected. (d). Drain device inoperative. (e). Tank insecure or inadequately mounted.	MiD MaD MiD MaD MaD

1.1.10. BRAKE SERVO UNITS, VALVES, MASTER CYLINDER, (HYDRAULIC SYSTEMS)

Method of testing

Carry out the following checks (where possible) on the components while the braking system is applied.

1. Check servo(s), valves and master cylinder(s) for presence, operation and condition.
2. Check for the presence of a cap on the master cylinder reservoir and for sufficient brake fluid level.

Notes

- Applied brakes means the braking system is pressurised using either the brake tool or a tester may use an assistant to apply the brakes.

CHECK ITEMS	REASONS FOR FAILURE	SEVERITY
Check:		
a. Security and condition.	(a). Servo/valve(s) is insecure or defective, damaged or badly corroded, sticking, leaking, brake performance not impaired.	MaD
b. Operation (brake performance impaired).	(b). Servo is non-operative, brake performance impaired.	DD
c. Operation (brake performance not impaired).	(c). Master cylinder/reservoirs defective but brake performance not impaired.	MaD
d. Defects, operation and leaks.	(d). Master cylinder/reservoirs defective and non-operative or leaking brake performance impaired.	DD
e. Security.	(e). Brake master cylinder/reservoirs are insecurely mounted or mounting panel is cracked but brake performance not impaired.	MaD
f. Security (brake performance impaired).	(f). Master cylinder/reservoirs defective and nonoperative or leaking, brake performance impaired.	DD
g. Brake fluid level.	(g). Insufficient brake fluid below MIN mark (less than half full or is below manufacturer's "minimum" level).	MiD
h. Brake fluid level (significantly low).	(h). Brake fluid significantly below MIN mark.	MaD
i. Brake fluid level (not visible).	(i). No brake fluid visible.	DD
j. Presence and condition of reservoir cap.	(j). Reservoir cap is leaking or cap missing.	MiD
k. Warning device.	(k). Brake fluid warning light illuminated or defective.	MiD
l. Warning device function.	(l). Incorrect functioning of brake fluid level warning device.	MiD
m. Repair or modification.	(m). Any obviously unsafe repair or modification to brake master cylinder/ servo/valves/connections.	MaD
n. Security (brake performance impaired).	(n). Master cylinder insecure and brake performance impaired.	DD

1.1.11. RIGID BRAKE PIPES

Method of testing

Carry out the following checks on all rigid brake pipes while the braking system is applied.

1. Check all accessible rigid brake pipes for general condition and fouling by a moving part.
2. Check all accessible rigid brake pipes, to ensure that they are in serviceable condition, free from chafing and external corrosion and damage.
3. Check that rigid pipes are securely held by clips or other means and examine brake pipes for repair or use of unsuitable fittings.

Notes

- When retesting a vehicle which required the repair or replacement of any hydraulic brake pipe(s), the items which failed must be re-tested as per method of testing above, under pressure on a raised lift, and a full brake test must be conducted.
- To correctly assess the condition of corroded metal brake pipes, surface dirt might have to be removed. This might require light scraping. Care must be taken not to damage any protective coating. Slight surface corrosion should not be considered a reason for failure.
- A missing brake pipe clip is not necessarily a reason for failure provided the brake pipe remains adequately supported.
- Couplings in brake pipes are acceptable provided they have been fitted to a high standard of workmanship. Repairs to hydraulic lines using copper tubing is acceptable provided suitable connectors are used.
- Provided the vacuum is maintained in the servo, the engine may be stopped.

CHECK ITEMS	REASONS FOR FAILURE	SEVERITY
Check for: a. Risk of failure / fracture. b. Leaks. c. Condition. d. Mounting / security. e. Fouling. f. Repairs. g. Condition.	(a). Imminent risk of failure or fracture. (b). Leaks are present in pipes or connections. (c). Are perished, kinked, damaged or rusted to the extent that the pipe is pitted. (d). Are unsatisfactorily mounted (or misplaced) with the possibility of failing. (e). A pipe is fouling moving parts. (f). Inadequate repairs have been carried out to pipes or unsuitable fittings are present ² . (g). Pipes damaged or excessively corroded that braking performance is affected.	DD DD MaD MaD MaD MaD DD

1.1.12. FLEXIBLE BRAKE HOSES

Method of testing

Carry out the following checks on all flexible brake hoses while the braking system is applied.

1. Check all flexible hoses, to ensure that they are not constrained in tight bends, that they have adequate room to move as necessary without fouling any other parts of the vehicle, and that they are not chafed, kinked, twisted or deteriorated and that they are in serviceable condition.
2. Check all brake hoses on steered axles when the steering is placed on either full lock ensure that there is adequate length of hose / sufficient clearance of other vehicle components.
3. Check that hoses are securely held by clips or other means and examine brake hoses for repair or use of unsuitable fittings.

Notes

- When retesting a vehicle which required the repair or replacement of any hydraulic brake hose, the items which failed must be re-tested as per method of testing above, under pressure on a raised lift, and a full brake test must be conducted.
- A missing brake hose clip is not necessarily a reason for failure provided the brake hose remains adequately supported.
- Provided the vacuum is maintained in the servo, the engine may be stopped.
- A flexible brake hose should only be considered a reason for failure when the reinforcement material / cord is exposed under examination.

CHECK ITEMS	REASONS FOR FAILURE	SEVERITY
Check:		
a. Risk of failure / fracture.	(a). Imminent risk of failure or fracture.	DD
b. Condition.	(b). Hoses perished, porous, kinked, twisted, too short or excessively damaged or chafed.	MaD
c. Leaks.	(c). Leaks are present in hoses or connections.	DD
d. Bulging.	(d). A hose is bulging under pressure.	MaD
e. Bulging.	(e). A hose is bulging under pressure (Cord impaired).	DD
f. Mounting.	(f). Hoses are unsatisfactorily mounted (or misplaced) with the possibility of failing.	MaD
g. Fouling.	(g). A hose is fouling moving parts.	MaD
h. Repairs.	(h). Inadequate repairs have been carried out to pipes or hoses or unsuitable fittings are present.	MaD

1.1.13. BRAKE LININGS AND PADS

Method of testing

1. Visually inspect brake pads and linings which can be seen without dismantling. Check for presence, security of pads/linings, excessive wear and contamination by leaking brake fluid, oil or grease. Also check for correct mounting and adjustment of lining or pad.
2. Check if there has been any repair or modification carried out to any of the mechanical components of the brake system.

Notes

- When retesting a vehicle which required the repair or replacement of any brake linings or pads, the items which failed must be re-tested as per method of testing above, on a raised lift, and a full brake test must be conducted.
- In the absence of wear indicators or manufacturer's recommendations regarding brake lining or disc pad wear, a figure of 1.5mm should be taken as a minimum thickness for bonded linings/pads. Where no facility is provided for inspection of brake shoes/pads this will not apply.
- Some vehicles have a warning light on the dashboard to indicate that the brake pads are becoming excessively worn. This lamp may be a multi-function lamp which also illuminates for other reasons (e.g. handbrake applied). Before failing brake pads under the reasons for failure below relating to wear (where a lamp is illuminated), testers must first ensure that the lamp is not illuminated for any other reason.
- In the absence of a manufacturer's tolerance insufficient contact means less than three quarters of the central pad surface with the disc.
- An unsafe repair or modification carried out to any of the mechanical components of the brake system, may require a modifications report to be presented as per the template in this Manual.

Advisory Pass applies where the brake pads/ linings are close to minimum wear mark.

CHECK ITEMS	REASONS FOR FAILURE	SEVERITY
Check:		
a. Wear (minimum mark reached).	(a). Lining or pad excessively worn/warning light illuminated (minimum mark reached).	MaD
b. Excessive wear (minimum mark not visible).	(b). Lining or pad excessively worn (minimum mark not visible).	DD
c. Contamination.	(c). Lining or pad contaminated (oil, grease etc.).	MaD
d. Excessive contamination (brake performance affected).	(d). Lining or pad contaminated that braking performance is affected.	DD
e. Presence and security.	(e). Lining or pad missing or wrongly mounted.	DD
f. Adjustment.	(f). Linings or pads are incorrectly adjusted.	MaD

1.1.14. BRAKE DRUMS, BRAKE DISCS

Method of testing

1. Visually inspect brake drums / discs which can be seen without dismantling. Check for presence, security of brake drums/discs and back plates. Check for excessive wear and contamination by leaking brake fluid, oil or grease. Also check for correct mounting and adjustment of brake drums/discs.
2. Check for fractures, damage, insecurity or misalignment of brake drums or discs or any disc or drum excessively worn beyond manufacturer's limit.
3. Check for evidence of sufficient contact between brake pad and brake disc.

Notes

- When retesting a vehicle which required the repair or replacement of any brake drum or disc, the items which failed must be re-tested as per method of testing above, on a raised lift and a full brake test must be conducted.
- In the absence of a manufacturer's tolerance insufficient contact means less than three quarters of the central pad surface with the disc.
- In the absence of a manufacturer's tolerance for excessive brake disc wear is 3mm or greater.
- Drum / disc ovality should only be considered a reason for failure when it affects the brake performance on a road test i.e. the presence of brake judder or pulling to one side, or the ovality can be felt through movement in the brake pedal.

CHECK ITEMS	REASONS FOR FAILURE	SEVERITY
Check:		
a. Wear.	(a). Drum or disc worn.	MaD
b. Excessive wear, condition and security.	(b). Drum or disc, excessively worn, scored, cracked, insecure or so fractured that failure is imminent.	DD
c. Contamination.	(c). A drum / disc is contaminated (oil, grease, etc.).	MaD
d. Excessive contamination (brake performance affected).	(d). A drum / disc is contaminated that braking performance is affected.	DD
e. Presence.	(e). Drum, disc or back plate missing.	DD
f. Security and condition.	(f). Back plate loose damaged or insecure.	MaD
g. Security.	(g). Dirt shield / dust cover loose or insecure.	MaD
h. Sufficient contact.	(h). Insufficient contact between brake pad and brake disc.	MaD

1.1.15. BRAKE CABLES, RODS, LEVERS, LINKAGES

Method of testing

1. Visually check the brake cables, rods, levers, linkages which can be seen without dismantling. Check brake rods, clevis joints, linkages, relay levers, pins, pivots or cables for damage, condition and correct adjustment.
2. Check that locking device is effective, secure and present.
3. Check the condition and completeness of brake cables and condition (frayed or seized) of cable guides for chafing rods or levers.
4. Check if there has been any obvious repair or modification carried out to any of the mechanical components of the brake system. An unsafe repair or modification carried out to any of the mechanical components of the brake system, may require a modifications report to be presented as per the template in this Manual.

Notes

- When retesting a vehicle which required the repair or replacement of any brake cables, rods, levers or linkages, the items which failed must be re-tested as per method of testing above, on a raised lift and a full brake test must be conducted.

CHECK ITEMS	REASONS FOR FAILURE	SEVERITY
Check: a. Condition. b. Condition (excessive wear). c. Security. d. Cable guide condition. e. Free movement. f. Maladjustment. g. Incorrect fitment. h. Retaining device presence, security and wear. i. Repair or modification.	(a). A brake rod / lever / cable / linkage / pivot is missing, damaged, cracked, corroded, knotted, seized, obstructed or worn. (b). A brake rod / lever / cable / linkage / pivot is missing, damaged, cracked, corroded, knotted, seized, obstructed or worn that braking performance is affected. (c). Cable, rod or joint insecure. (d). Cable guide defective. (e). Restriction to free movement of the braking system. (f). Abnormal movement of the levers/linkage indicating maladjustment or excessive wear. (g). A brake rod / lever / cable / linkage / pivot is incorrectly fitted. (h). A bracket, mounting bolt, split pin or other retaining device is missing, loose or worn. (i). Any obviously unsafe repair or modification ² .	MaD DD MaD MaD MaD MaD MaD MaD MaD

1.1.16. BRAKE ACTUATORS (INCLUDING SPRING BRAKES / CALLIPERS / HYDRAULIC CYLINDERS)

Method of testing

1. Visually inspect each brake wheel unit / callipers for security, leaks, corrosion or damage. By applying the brakes check each brake wheel unit for leaks and where possible, operation. Check that all appropriate items e.g. fixing nuts, bolts and split pins are secure and locked.
2. Check brake actuators (including spring brakes / callipers / hydraulic cylinders) for fluid discharge, dust cover presence and condition (only applicable to hydraulic brake actuators).
3. Check each brake cylinder/actuator are of the same size (where fitted to the same axle). Check for travel of operating pistons/diaphragms and mechanisms.
4. Check if there has been any obvious repair or modification carried out to any of the components of the brake system. An unsafe repair or modification carried out to any of the mechanical components of the brake system, may require a modifications report to be presented as per the template in this Manual.

Notes

- When retesting a vehicle which required the repair or replacement of any brake actuators (callipers / hydraulic cylinders), the items which failed must be re-tested as per method of testing above, under pressure on a raised lift and a full brake test must be conducted.
- The parking brake should be released during this test.
- An unsafe repair or modification carried out to any of the mechanical components of the brake system, may require a modifications report to be presented as per the template in this Manual.

Advisory Pass applies in the case of a dust cover damaged on a brake actuator.

CHECK ITEMS	REASONS FOR FAILURE	SEVERITY
Check:		
a. Condition, security and adjustment.	(a). An actuator/lever is damaged, cracked insecure, inadequately mounted or is in need of adjustment.	MaD
b. Condition, security and adjustment (brake performance affected).	(b). An actuator/lever is damaged, cracked insecure, inadequately mounted or is in need of adjustment that braking performance is affected.	DD
c. Leaks.	(c). Actuator leaking.	MaD
d. Excessive leaks.	(d). Actuator leaking that braking performance is affected.	DD
e. Operation.	(e). Sluggish in operation/restricted or seized.	MaD
f. Excessive corrosion.	(f). Actuator excessively corroded.	MaD
g. Excessive corrosion.	(g). Actuator likely to crack.	DD
h. Actuator compatibility.	(h). Different sized actuators fitted to the same axle.	MaD
i. Travel.	(i). Insufficient or excessive travel of operating piston or diaphragm mechanism.	MaD
j. Free movement (brake performance affected).	(j). Braking performance affected (lack of reserve movement).	DD
k. Dust cover presence and damage.	(k). Dust cover missing or excessively damaged.	MaD
l. Repair or modification.	(l). Any obviously unsafe repair or modification ² .	MaD

1.1.17. LOAD SENSING VALVE

Method of testing

1. Check that load sensing / brake proportioning valves are not missing, bypassed, linkage sticking, disconnected, damaged, leaking or inoperative and are correctly adjusted.
2. Visually inspect the load sensing / brake proportioning valves while the braking system is applied for signs of leaks.

Notes

- When retesting a vehicle which required the repair or replacement of any load sensing/proportioning valve, the items which failed must be re-tested as per method of testing above, under pressure on a raised lift and a full brake test must be conducted.
- There is no requirement for a load sensing valve data plate on the vehicle.

CHECK ITEMS	REASONS FOR FAILURE	SEVERITY
Check:		
a. Condition (linkage).	(a). Defective linkage.	MaD
b. Operation (ABS/EBS functioning).	(b). Valve seized or inoperative (ABS/EBS functioning).	MaD
c. Operation.	(c). Valve seized or inoperative.	DD
d. Presence or bypassed.	(d). Valve missing or bypassed (if required).	DD
e. Security and leaks.	(e). A valve insecurely mounted, leaking or defective.	MaD
f. Condition and adjustment.	(f). The load sensing or brake proportioning valves are damaged, inoperative, obviously incorrectly adjusted or a linkage is sticking.	MaD

1.1.18. SLACK ADJUSTER AND INDICATORS

Method of testing

1. Check for the presence, condition and operation of slack adjusters.
2. Check for excessive wear, defects and correct operation.

CHECK ITEMS	REASONS FOR FAILURE	SEVERITY
Check:		
a. Condition and operation (adjuster).	(a). Adjuster damaged, seized or having abnormal movement, excessive wear or incorrect adjustment.	MaD
b. Condition (adjuster).	(b). Adjuster defective.	MaD
c. Fitment	(c). Incorrectly installed or replaced.	MaD

1.1.21. COMPLETE BRAKING SYSTEM

Method of testing

1. Visually check other brake system devices (where fitted) e.g. anti-freeze pump, air dryer, etc. for external damage, excessive corrosion or leakage.
2. Check if there has been any obvious repair or modification carried out to any of the components of the brake system. An unsafe repair or modification carried out to any of the mechanical components of the brake system, may require a modifications report to be presented as per the template in this Manual.

Notes

- It is inevitable that due to changes in design, or other reasons, from time to time defects may be found which are not described in any of the reasons for failure in the other sections of this Manual. Therefore this section is to be used in cases only where a particular braking related component is not checked under another section of this Manual.
- An unsafe repair or modification carried out to any of the mechanical components of the brake system, may require a modifications report to be presented as per the template in this Manual.

CHECK ITEMS	REASONS FOR FAILURE	SEVERITY
Check: a. Condition. b. Condition (braking performance is affected). c. Leaks. d. Excessive leaks. e. Security. f. Repair or modification. g. Repair or modification (braking performance is affected).	(a). Other system devices damaged externally or excessively corroded in a way that adversely affects the braking system. (b). Other system devices damaged that braking performance is affected. (c). Slight leakage of air or anti-freeze. (d). Excessive leakage of air that system functionality is affected. (e). Any component insecure or inadequately mounted. (f). Unsafe modification to any component ² . (g). Unsafe modification to any component ² that braking performance is affected.	MaD DD MiD MaD MaD MaD DD

1.1.22. TEST CONNECTIONS (WHERE FITTED OR REQUIRED)

Method of testing

1. Visually check test connections are not missing, disconnected, damaged, leaking or unusable.
2. Visually inspect the test connections while the braking system is applied for signs of leaks.

CHECK ITEMS	REASONS FOR FAILURE	SEVERITY
Check: a. Presence. b. Condition and leaks.	(a). Missing. (b). Damaged, unusable or leaking.	MaD MaD

1.2. Service Braking Performance & Efficiency (Roller Brake Test)

1.2.1. PERFORMANCE (IMBALANCE) & 1.2.2. EFFICIENCY

Method of testing

1. If the Vehicle is of a type which can be tested on a roller brake tester proceed as follows:

- (a). Drive the vehicle so that the wheels of each axle can in turn be placed onto the roller brake tester. Following the prompts of the brake tester programme apply the service brake. The braking efficiency is calculated against the test weight of the vehicle.
- (b). Check that the brake can be applied progressively and when released does not show any abnormal lag.

Notes

- Tyres must be correctly inflated and the gear selector should be in the neutral position.
- If the tester has any doubt regarding the service brake configuration then a decelerometer test must be conducted.
- The testing of vehicles fitted with ice studded tyres will damage the brake tester roller friction surface. It is advisable to ensure before the roller brake test that the tyres are not damaged and are free from stones embedded in the tread.
- Vehicles having automatic transmission must not be tested with the gear selector in the “P” park position.
- Occasions will arise when the required brake efficiency is just obtained or just exceeded without lock occurring but the tester knows that a higher efficiency figure is normally obtainable for the type of vehicle being tested. In such cases although the vehicle has passed the brake efficiency test, the tester should advise the owner that the braking system appears to be in need of adjustment or repair.
- For vehicles with servo assisted or power braking systems, the engine must be running (idling) when the service brake is tested.
- In some cases it may be necessary to chock the road-wheels of the vehicle during a roller brake test.
- Care should be taken to ensure that tyres are free from mud, stones, oil, or water and that brake tester rollers are in good condition to ensure that premature wheel slip does not occur.
- Where a vehicle cannot be tested on a roller brake tester because of additional spoilers fitted, they must be removed by the owner/presenter before the test. A decelerometer test will not suffice in this situation.
- In the case of a vehicle which attains the braking effort specified in Roadworthiness Directive for vehicles tested at their Design Gross Vehicle Weight but does not attain the braking effort specified in the Road Traffic (National Car Test) Regulations when tested at the test[ed] weight but complies with every other requirement of the service brake performance test, if the applicant for the test supplies proof that the vehicle has braking type approval to European Economic Community Directive 71/320/EEC and proof of the Design Gross Vehicle Weight of the vehicle to the Road Safety Authority then the Road Safety Authority will consider whether the vehicle should be retested.

A tester may refuse to carry out the service brake efficiency test on a vehicle if in his or her opinion the braking system is in such a condition that it would not be safe to carry out the test.

Where a brake test is not carried out on a vehicle this must be recorded on the test report using the option on the NCTS system.

1.2. Service Braking Performance & Efficiency (Decelerometer Test)

1.2.1. PERFORMANCE (IMBALANCE) & 1.2.2. EFFICIENCY

Method of testing

1. If the vehicle is of a type that cannot be tested on the roller brake tester it should be subjected to a decelerometer test as follows:

- (a). With the vehicle on a reasonably level road, set the decelerometer on the vehicle in line with the manufacturer's instructions.
- (b). If a road test is carried out this should be done in traffic free circumstances, have the vehicle driven at a steady speed between 32 – 48 km/h (20 – 30 M.P.H) on level ground. Have the service brake applied firmly and note the reading on the decelerometer. Note whether the vehicle pulls to one side when the brakes are applied and if there is any evidence of brake drum / disc ovality.
- (c). Check items a, b, c, d & g only apply to a roller brake test.

1.2.1. PERFORMANCE (IMBALANCE)

CHECK ITEMS	REASONS FOR FAILURE	SEVERITY
Check:		
a. Brake wheel effort (less than 25 kN).	(a). The brake effort on any wheel is less than .25 kilonewtons (kN).	MaD
b. Brake wheel effort (no braking effort).	(b). No brake effort on one or more wheels.	DD
c. Brake imbalance.	(c). More than 30% difference is present in braking effort between wheels on the same axle (i.e. the brake effort on one side should not be less than 70% of the braking effort on the other side).	MaD
d. Brake imbalance (steered axles).	(d). Brake effort from any wheel is less than 50% of the maximum effort recorded from the other wheel on the same axle in the case of steered axles.	DD
e. Gradual brake effort.	(e). No gradual variation in brake effort (grabbing).	MaD
f. Brake lag.	(f). The brake shows abnormal lag when released	MaD
g. Brake fluctuation.	(g). Excessive fluctuation of brake force, on an individual wheel brake effort fluctuates by more than 30%.	MaD
h. Obvious pull to one side (road test).	(h). Where a road test is carried out, obvious pull to one side is present when brakes are applied.	MaD
i. Perceptible ovality (road test).	(i). Where a road test is carried out, perceptible ovality is present in the service brake.	MaD
j. Progressive operation.	(j). The brake cannot be operated progressively.	MaD

1.2.2. EFFICIENCY

CHECK ITEMS	REASONS FOR FAILURE	SEVERITY
Check:		
a. Efficiency.	(a). (i) The braking effort for vehicles registered on or after 28 July 2010 is less than 58% of the test weight of the vehicle. (ii) The braking effort for vehicles registered before 28 July 2010 is less than 55% of the test weight of the vehicle.	MaD
b. Efficiency (less than 50% of required).	(b). (i) The brake effort for vehicles registered on or after 28 July 2010 is less than 29% of the test weight of the vehicle. (ii) The brake effort for vehicles registered before 28 July 2010 is less than 27.5% of the test weight of the vehicle.	DD

1.4. Parking Brake Performance & Efficiency

1.4.1. PERFORMANCE (IMBALANCE) & 1.4.2 (EFFICIENCY)

Method of Testing

Roller Brake Test

- Normally this test and the service brake test will be carried out concurrently and the same general precautions apply (see “method of testing” and “notes” for service brake performance).
 - With the roller brake tester driving each road wheel in turn apply the parking brake slowly until each road wheel is just at the point of slip relative to the rollers, or until sufficient braking is achieved, whichever occurs first. Note the braking effort indicated from the brake at each road wheel, and calculate the total braking force available. Calculate the braking efficiency as a percentage of the test weight of the vehicle.
 - If the parking brake is a transmission brake, all wheels on the axle braked by it must be driven by the roller brake tester at the same time. It should be remembered that if a transmission brake is fully applied and the wheels of the axle being tested are still turning, then the readings obtained are the maximum that can be attributed to that transmission brake.

Decelerometer Test

- If the vehicle is of a type which cannot be tested on the roller brake tester, it should be subject to decelerometer test as follows:
 - With the vehicle on a reasonably level road, set the decelerometer on the vehicle in accordance with the instrument manufacturer’s instructions;
 - Have the vehicle driven at a speed of approximately 32kph (20mph). Have the parking brake applied and note the reading on the decelerometer (see note).
- For both methods above, check whether the vehicle pulls to one side when the brakes are applied.

Notes

- On certain vehicles the parking brake cannot be tested dynamically. Tester should check manufacturer’s recommendations in such cases.

CHECK ITEMS	REASONS FOR FAILURE	SEVERITY
Check for: a. Imbalance.	(a). Where a road test is carried out, the vehicle deviates excessively from a straight line.	MaD
b. Imbalance.	(b). More than 50% difference is present in brake effort between wheels on the same axle.	MaD

1.4.2. EFFICIENCY

CHECK ITEMS	REASONS FOR FAILURE	SEVERITY
Check: a. Efficiency (less than 16%).	(a). The brake effort is less than 16% of the test weight of the vehicle.	MaD
b. Efficiency (more than 50% difference).	(b). The brake effort achieved for the vehicle is less than 50% of minimum required.	DD

1.6. Anti-lock braking system (ABS)

1.6. ANTI-LOCK BRAKING SYSTEM (ABS)

Method of Testing

1. If the vehicle is fitted with an Anti-Lock Braking System (ABS), check that the relevant warning lamp is fitted, and follows the correct sequence of operation (manufacturer's check sequence must be verified).
2. Where possible connect OBD scan tool and check for error codes.
3. Visually check wheel speed sensors are not damaged or missing.
4. Check wiring or other components are not damaged or missing.

Notes

- When retesting a vehicle which required the repair or replacement of any ABS component(s) or malfunction indicator, the items which failed must be re-tested as per method of testing above, and a full brake test must be conducted.
- Where the warning light sequence is not as per the light sequence chart but the owner/ presenter states that the operation is correct but different from the normal sequence, then a tester may request verification for the light sequence for that particular vehicle from an authorised dealer or from the vehicle manufacturer.
- Reasons for failure (f) & (g) will not apply until further notice.
- Reason for failure (g) applies where the OBD scan tool fails to communicate with the vehicle interface or the OBD port is damaged.

Advisory Pass applies where an error code is detected that is not a reason for failure.

CHECK ITEMS	REASONS FOR FAILURE	SEVERITY
Check for:		
a. Malfunction indicator.	(a). Malfunction indicator light, not working, not going through the correct sequence or indicates any kind of failure of the system.	MaD
b. Presence and condition (speed sensors).	(b). Wheel speed sensors missing or damaged.	MaD
c. Condition (wiring).	(c). Wiring damaged.	MaD
d. Presence and condition (other components).	(d). Other components missing or damaged.	MaD
e. Removal / tampering.	(e). Removed or disabled.	MaD
f. Malfunction indicator (vehicle interface).	(f). System indicates failure via the electronic vehicle interface.	MaD
g. Vehicle interface with OBD scan tool.	(g). Communication failure with the electronic vehicle interface.	MaD

1.7. Electronic Brake System (EBS)

1.7. ELECTRONIC BRAKE SYSTEM (EBS)

Method of Testing

1. Check that the EBS malfunction indicator follows the correct sequence of operation or does not indicate a defect in the system (manufacturer's check sequence must be verified).
2. Where possible connect OBD scan tool and check for error codes.
3. Visually check wheel speed sensors are not damaged or missing.
4. Check wiring or other components are not damaged or missing.

Notes

- When retesting a vehicle which required the repair or replacement of any EBS component(s) or malfunction indicator, the items which failed must be re-tested as per method of testing above, and a full brake test must be conducted.
- Where the warning light sequence is not as per the light sequence chart but the owner/ presenter states that the operation is correct but different from the normal sequence, then a tester may request verification for the light sequence for that particular vehicle from an authorised dealer or from the vehicle manufacturer.
- Reasons for failure (f) & (g) will not apply until further notice.
- Reason for failure (g) applies where the OBD scan tool fails to communicate with the vehicle interface or the OBD port is damaged.

Advisory Pass applies where an error code is detected that is not a reason for failure.

CHECK ITEMS	REASONS FOR FAILURE	SEVERITY
Check for:		
a. Malfunction indicator.	(a). Malfunction indicator light, not working, not going through the correct sequence or indicates any kind of failure of the system.	MaD
b. Presence and condition (speed sensors).	(b). Wheel speed sensors missing or damaged.	MaD
c. Condition (wiring).	(c). Wiring damaged.	MaD
d. Presence and condition (other components).	(d). Other components missing or damaged.	MaD
e. Removal / tampering.	(e). Removed or disabled.	MaD
f. Malfunction indicator (vehicle interface).	(f). System indicates failure via the electronic vehicle interface.	MaD
g. Vehicle interface with OBD scan tool.	(g). Communication failure with the electronic vehicle interface.	MaD

1.8. Brake Fluid

1.8. BRAKE FLUID

Method of Testing

1. Visually check the brake fluid reservoir for security and condition of fluid.

Notes

- If the brake fluid cannot be easily seen without removing the reservoir cap, then the cap must be removed for inspection.

CHECK ITEMS	REASONS FOR FAILURE	SEVERITY
Check for: a. Contamination. b. Excessive contamination.	(a). Brake fluid contaminated or sedimented. (b). Brake fluid is excessively contaminated that there is imminent risk of failure.	MaD DD

2. STEERING

CONTENTS

2.1. MECHANICAL CONDITION40
2.1.1. STEERING GEAR CONDITION (RACK AND PINION, STEERING BOX)	40
2.1.2. STEERING GEAR CASING ATTACHMENT	41
2.1.3. STEERING LINKAGE CONDITION (IDLER ASSEMBLY, TRACK ROD/STEERING ARM)	42
2.1.4. STEERING LINKAGE OPERATION	43
2.1.5. POWER STEERING.	44
2.2. STEERING WHEEL & COLUMN45
2.2.1. STEERING WHEEL CONDITION	45
2.2.2 STEERING COLUMN/STEERING WHEEL	46
2.3. STEERING PLAY47
2.4. WHEEL ALIGNMENT48
2.6. ELECTRONIC POWER STEERING (IF FITTED)49

2. STEERING

2.1. Mechanical Condition

2.1.1. STEERING GEAR CONDITION (RACK AND PINION, STEERING BOX)

Method of testing

1. Position the vehicle on a raised lift with the steered axle aligned over the wheel play detector plates with the brakes applied. Using the wheel play detectors, check the steering mechanism from the point it is secured to the chassis, to the point where the steering arms are secured to their fixings.
2. Check for roughness or stiffness in the steering gear operation.
3. Check steering rack gaiter condition and security and check for any leaks in the system.
4. Check for welding of steering linkages other than by the manufacturer.
5. Check if there has been any obvious repair or modification carried out to any steering components. An unsafe repair or modification carried out to any of the mechanical components of the steering system, may require a modifications report to be presented as per the template in this manual.

Notes

- Expand steering rack gaiters for proper examination.
- All steered wheels must be checked.
- Certain vehicles have a built-in play in the steering rack mounting bushes and this should be taken into consideration.

Advisory Pass applies to a slight oil weep from the steering (rack or box).

CHECK ITEMS	REASONS FOR FAILURE	SEVERITY
Check for:		
a. Operation.	(a). Roughness or stiffness in operation of gears or bearings/bushings.	MaD
b. Condition.	(b). Sector shaft twisted or splines worn or damaged.	MaD
c. Condition (function affected).	(c). Sector shaft twisted or splines so worn or damaged that functionality is affected.	DD
d. Excessive wear (shaft).	(d). Excessive wear or movement in sector shaft.	MaD
e. Excessive wear (function affected).	(e). Excessive wear or movement in sector shaft that functionality is affected.	DD
f. Continuous oil leaks.	(f). Continuous oil leak is present from steering box/rack/ or steering damper.	DD
g. Condition and security (linkage).	(g). A linkage is damaged or insecure.	MaD
h. Oil leak.	(h). Obvious oil leak (formation of drops).	MaD
i. Excessive wear (bushes).	(i). Bushes/bearings are excessively worn.	MaD
j. End float.	(j). Excessive end float is present in pinion.	MaD
k. Steering gaiter.	(k). Steering rack gaiter is insecure, split or missing.	MaD
l. Condition and security (steering system).	(l). Steering system damaged, insecure or excessively worn.	DD
m. Repairs by welding.	(m). Any steering component has been repaired by welding (other than by the manufacturer).	MaD

2.1.2. STEERING GEAR CASING ATTACHMENT

Method of testing

1. Position the vehicle on a raised lift with the steered axle aligned over the wheel play detector plates with the brakes applied. Using the wheel play detectors, Check the steering gear casing attachment bolts. Visually check for relative movement between casing and chassis/bodywork.
2. Check the security of any part fixed to the vehicle structure, e.g. steering box, rack housing or intermediate drop arm pivot housing and check for cracks or corrosion around attachment points.

Notes

- It may be necessary to open the engine compartment to examine certain steering components on some vehicles (e.g. steering rack mounted on upper part of the bulkhead etc.).

CHECK ITEMS	REASONS FOR FAILURE	SEVERITY
Check for: a. Attachment. b. Attachment (function affected). c. Condition of fixings. d. Presence of fixings. e. Attachment. f. Steering gear condition. g. Steering gear condition (function affected). h. Corrosion.	(a). Steering gear casing not properly attached. (b). Steering attachments dangerously loose or relative movement to chassis/bodywork visible. (c). Elongated fixing holes in chassis. (d). A mounting bolt for steering housing is missing, loose or fractured. (e). Steering attachments seriously affected. (f). Steering gear casing/housing is fractured/damaged or worn. (g). Steering gear casing/housing is fractured/damaged or worn that directional stability is impaired, functionality affected, insufficient clearance to other vehicle parts. (h). Cracks or corrosion are present around attachment points for steering box, rack or idler box.	MaD DD MaD MaD DD MaD DD MaD

2.1.3. STEERING LINKAGE CONDITION (IDLER ASSEMBLY, TRACK ROD/STEERING ARM)

Method of testing

1. Position the vehicle on a raised lift with the steered axle aligned over the wheel play detector plates with the brakes applied using the wheel play detectors check the steering linkage condition.
2. Check the steering linkage condition, drop arm, drag link, track rods and track rod ends.
3. Check condition of rubber gaiters and dust covers.

With steered wheels off the ground (using the vehicle manufacturer's recommended jacking points):

4. Check for fouling of wheels, tyres and components of the steering linkage with any part of the vehicle by rotating the steering wheel through its full working range and also by checking likely fouling points for abrasion.
5. Grasp each steered wheel at 3 o'clock and 9 o'clock, and shake vigorously to determine the condition of the outer ball joints and track control arm inner bushes.
6. Check if there has been any obvious repair or modification carried out to any steering components. An unsafe repair or modification carried out to any of the mechanical components of the steering system, may require a modifications report to be presented as per the template in this Manual.

Notes

- Relative movement due to excessive wear must be distinguished from relative movement due to built-in clearance or spring loading of a joint

CHECK ITEMS	REASONS FOR FAILURE	SEVERITY
Check for: a. Security of components. b. Security of components (failure imminent). c. Joint wear. d. Joint wear (failure imminent). e. Condition and security (drag link/drop arm). f. Condition and security (drag/track rod ends). g. Condition of gaiters/ dust covers. h. Security (idler assembly). i. All components. j. All components (safety affected). k. Track rod and steering arm damage. l. Retaining devices. m. Component alignment. n. Repair or modifications. o. Repair or modification (safety affected).	(a). Relative movement between components which should be fixed. (b). Excessive movement or components are likely to become detached. (c). Excessive wear at joints. (d). Joint so excessively worn and likely to become detached. (e). A drop arm/drag link is damaged or insecure. (f). A drag link or the track rod ends are obviously worn or insecure (inner and outer). (g). Dust covers/gaiter split, damaged, missing or severely deteriorated/displaced. (h). Idler assembly mounting is obviously loose, or axial or radial play is present in the assembly. (i). Fractures or deformation of any component. (j). Fractures or deformation of any component that function is affected. (k). Track rod/steering arm is obviously deformed, loose or cracked. (l). A retaining or locking device (split pin, nut, rivet, weld, etc.) is missing, insecure, worn or broken. (m). Misalignment of components (e.g. track rod or drag link). (n). Any obviously unsafe repair or modification to any steering component. (o). Any steering modification ² affecting steering function.	MaD DD MaD DD MaD MaD MaD MaD MaD DD MaD MaD MaD MaD DD

2.1.4. STEERING LINKAGE OPERATION

Method of testing

1. Position the vehicle on a raised lift with the steered axle aligned over the wheel play detector plates with the brakes applied using the wheel play detectors check the steering linkage operation.
2. Check that the steering linkage is operating correctly with the front road wheels off the ground. Turn the steering wheel in both directions lock to lock checking for fouling, presence, security and correct adjustment of lock stops if fitted.

Notes

- A missing steering lock stop should only be failed where it is known to have been fitted as standard.
- Many modern vehicles are fitted with electro hydraulic steering systems, if the wheels are rotated through their full working range without the engine running this may lead to cavitation of the system.
- Welding of steering parts other than by a manufacturer is not acceptable.

CHECK ITEMS	REASONS FOR FAILURE	SEVERITY
Check for: a. Fouling. b. Operation and presence (steering stops). c. Steering operation.	(a). Moving steering linkage fouling a fixed part of the chassis. (b). Steering stops not operating or missing. (c). Steering overlocking / underlocking or fouling any other component on the vehicle.	MaD MaD MaD

2.1.5. POWER STEERING

Method of testing

1. Check that the power steering is operating with the front road wheels on the ground and with the engine running, turn the steering wheel in both directions.
2. Check fluid level and for leaks in the power steering system and fouling of fluid pipes.
3. Check for corrosion and security/damage of power steering components.
4. Check if there has been any obvious repair or modification carried out to any steering components. An unsafe repair or modification carried out to any of the mechanical components of the steering system, may require a modifications report to be presented as per the template in this Manual.

Notes

- Many modern vehicles are fitted with electro hydraulic steering systems, if the wheels are rotated through their full working range without the engine running this may lead to cavitation of the system.
- If power steering is fitted, the engine may need to be left running for all checks requiring steering movement.

CHECK ITEMS	REASONS FOR FAILURE	SEVERITY
Check for: a. Intermittent operation. b. Operation. c. Fluid level. d. Leaks. e. Fouling of pipes. f. Fluid pipe condition. g. Fluid pipe condition (steering affected). h. Security of components. i. Security of components (steering affected). j. Steering pump condition. k. Modifications. l. Modifications (steering affected).	(a). Power assistance is not available consistently over full lock to lock range. (b). Power assistance is not operating, is disconnected or is missing where power steering is a standard fitment by the manufacturer on all vehicles of the type (make and model) of vehicle being tested. (c). Power steering fluid level is below minimum level. (d). Leaks are present in power steering system. (e). A power steering fluid pipe is fouling other components. (f). Fluid pipes/hoses damaged, excessively corroded. (g). Fluid pipes/hoses or cables so damaged that steering is affected. (h). Any power steering component not working, worn, fractured, misaligned or insecure. (i). Any power steering component not working, fractured, misaligned, worn or insecure that steering is affected. (j). Power steering pump is worn, noisy, leaking or has a defective drive. (k). Unsafe modification to any component ² . (l). Unsafe modification to any component ² that steering is affected.	MaD MaD MaD MaD MaD MaD DD MaD DD MaD MaD DD

2.2. Steering Wheel & Column

2.2.1. STEERING WHEEL CONDITION

Method of testing

1. Check the strength and condition (including any modifications) of the steering wheel by applying reasonable force.
2. Push the steering wheel rim in various directions at right angles to the column, while applying light pressure downward and upward

Notes

- Cracks or incompleteness of the covering skin of a steering wheel or hub are not a reason for failure.

CHECK ITEMS	REASONS FOR FAILURE	SEVERITY
Check for: a. Attachment. b. Attachment (failure imminent). c. Condition. d. Condition (failure imminent).	(a). Relative movement between steering wheel and column indicating looseness. (b). Excessive movement in the steering wheel that there is a very serious risk of becoming detached. (c). Fracture or looseness of steering wheel hub, rim or spokes or absence of retaining device. (d). Fracture or looseness of steering wheel hub, rim or spokes or absence of retaining device that there is a very serious risk of becoming detached.	MaD DD MaD DD

2.2.2 STEERING COLUMN/STEERING WHEEL

Method of testing

Before carrying out this inspection, make sure that any mechanism for adjusting the steering column is fully locked.

1. Rock the steering wheel from side to side and note any relative movement between the steering column and wheel. Apply slight downward and upward pressure to the rim of the steering wheel with both hands and note the condition of the steering wheel hub and rim.
2. Attempt to lift the steering wheel in line with the steering column and note any movement at the centre of the steering wheel or of the steering column.
3. Push steering wheel away and pull it towards the body, and note the movement of the steering column radially and its security of mounting.
4. Check the universal joints/flexible couplings for wear security or deterioration.
5. Check the presence and security of retaining and locking devices.
6. Check if there has been any obvious repair or modification carried out to the steering wheel/column/shaft or to the universal joint/clamp. An unsafe repair or modification carried out to any of the mechanical components of the steering system, may require a modifications report to be presented as per the template in this Manual.

Notes

- Where a steering mechanism is fitted with flexible couplings care must be taken to distinguish between play due to wear, and apparent play due to the construction of the mechanism.

CHECK ITEMS	REASONS FOR FAILURE	SEVERITY
Check for:		
a. Excessive movement (steering wheel).	(a). Excessive movement of centre of steering wheel up or down.	MaD
b. Excessive movement (column).	(b). Excessive movement of top of column radially from axis of column.	MaD
c. Security.	(c). Steering wheel / column / shaft has excessive end float, is insecure or broken.	MaD
d. Mounting brackets security.	(d). Any bush / bearings / mounting brackets for steering wheel / column / shaft is missing, worn, damaged or insecure.	MaD
e. Joints and couplings.	(e). Any universal joint / clamp/ flexible coupling damaged, worn, insecure or badly deteriorated.	MaD
f. Joints and couplings (failure imminent).	(f). Any universal joint / clamp/ flexible coupling damaged, worn, insecure or badly deteriorated that failure is imminent	DD
g. Shear pin.	(g). Shear pin in telescopic column is broken.	MaD
h. Locking device.	(h). Any retaining or locking device is missing or insecure.	MaD
i. Attachment.	(i). Steering wheel/column attachment is defective.	MaD
j. Attachment (failure imminent).	(j). Steering wheel/column attachment is so defective that there is very serious risk of detachment.	DD
k. Repairs and modifications.	(k). Unsafe repair or modification?	DD

2.3. Steering play

2.3 STEERING PLAY

Method of testing

1. With the road wheels on the ground and in the straight-ahead position, turn steering wheel until movement can be detected at the front road wheels. Align a reference mark on steering wheel with a mark on a ruler and slowly turn steering wheel in the opposite direction until movement can be detected at the front road wheel. Measure play at steering wheel. (Special play-checking instruments are also available, measuring free play in mm or degrees. Such instruments should always be mounted and used according to the manufacturer's instructions).

Notes

- Excessive rotational play (measured at the outer rim of the steering wheel):
 - Steering Box
 - 20° on 13" (330mm) diameter steering wheel = 60mm
 - 20° on 15" (381mm) diameter steering wheel = 69mm
 - 20° on 18" (457mm) diameter steering wheel = 83mm
 - Rack and Pinion
 - 5° on 13" (330mm) diameter steering wheel = 14mm
 - 5° on 15" (381mm) diameter steering wheel = 17mm
 - 5° on 18" (457mm) diameter steering wheel = 20mm

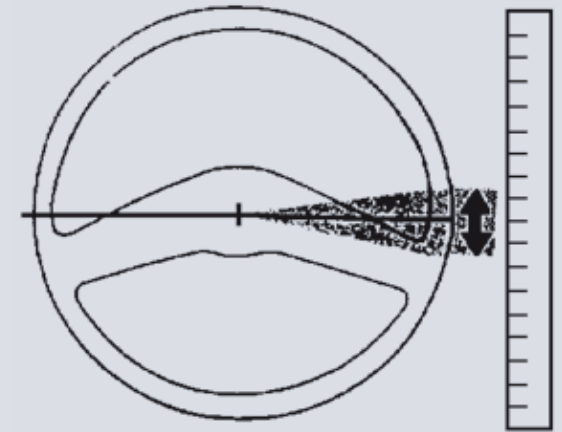

CHECK ITEMS	REASONS FOR FAILURE	SEVERITY
Check for: a. Excessive play (steering affected). b. Excessive play (steering box). c. Excessive play (rack and pinion).	(a). Free play in steering is so excessive that safe steering is affected. (b). Excessive rotational play (20° or more) is present in the steering box. (c). Excessive rotational play (5° or more) is present in the rack and pinion.	DD MaD MaD

2.4. Wheel Alignment

2.4 WHEEL ALIGNMENT

Method of testing

1. Drive a wheel of each axle in turn slowly and straight over the side slip plate without moving the steering wheel or applying the brakes.

Notes

- When explaining a reason for failure (in this section) to the vehicle owner/ presenter, side slip may be referred to as steering geometry.
- Where a vehicle is refused a Test certificate in relation to steering or suspension components, then it must have a steering alignment test (side slip) carried out on retest, (this does not apply to most anti-roll bar bushings or drop links).

CHECK ITEMS	REASONS FOR FAILURE	SEVERITY
Check for: a. Alignment. b. Alignment. c. Alignment.	(a). Front wheel alignment is more than +/- 14m/km (in the absence of manufacturer's data). (b). Rear wheel alignment is more than +/- 18m/km (in the absence of manufacturer's data). (c). Straight on driving affected; directional stability impaired.	MaD MaD DD

2.6. Electronic Power Steering (If fitted)

2.6 ELECTRONIC POWER STEERING (IF FITTED)

Method of testing

1. Check that the steered wheels are pointing straight ahead with the steering wheel in the straight ahead position and/or using the electronic vehicle interface.
2. Check that the electronic power steering is operating, by turning the steering wheel from lock to lock with the engine running and the road wheels on the ground.
3. Check the malfunction indicators for the Electronic Power Steering (EPS), Manufacturer's check sequence must be verified.

Notes

- Manually switched Electronic Park Assist designed to be activated when parking the vehicle is not a reason for failure if the power assistance is inoperative provided the function of the steering is not adversely affected.

CHECK ITEMS	REASONS FOR FAILURE	SEVERITY
Check for: a. EPS malfunction indicator sequence. b. Steering wheel angle with road wheels in a straight line position. c. Steering wheel angle with road wheels in a straight line position (function impaired). d. Power assistance. e. Malfunction indicators.	(a). Malfunction indicator light, not working, not going through the correct sequence or indicates any kind of failure of the system. (b). Inconsistency between the angle of the steering wheel and the angle of the wheels. (c). The angle of the steering wheel in relation to the road wheels is so misaligned that the steering is affected. (d). Power assistance not working. (e). System indicates failure via the electronic vehicle interface.	MaD MaD DD MaD MaD

3. VISIBILITY

CONTENTS

3.1. FIELD OF VISION51
3.2. CONDITION OF GLASS.52
3.3. REAR-VIEW MIRRORS OR DEVICES57
3.4. WINDSCREEN WIPERS58
3.5. WINDSCREEN WASHERS58
3.6. DEMISTING SYSTEM59

3. VISIBILITY

3.1. Field of Vision

3.1. FIELD OF VISION

Method of testing

1. Check that there is an adequate view from the driving seat and that it is not interfered with by objects or stickers.

Notes

- Official stickers such as tax, insurance and NCT discs are not considered a reason for failure provided they do not seriously restrict the drivers view.
- A sun visor fitted to the driver's side, which cannot be stowed in the 'off screen' position and which drops down obstructing the view of the road through the swept area of the windscreen may be considered a reason for failure.
- Wiper blades that automatically park in a position that obscures the view through the windscreen may be considered a reason for failure.

CHECK ITEMS	REASONS FOR FAILURE	SEVERITY
Check for: a. Obstruction, objects or stickers (outside cleaning area of windscreen wipers). b. Obstruction, objects or stickers (inside cleaning area of windscreen wipers).	(a). Obstruction, objects or stickers within driver's field of view that materially affects drivers view in front or to the sides (outside cleaning area of windscreen wipers). (b). Obstruction, objects or stickers within driver's field of view that materially affects drivers view in front or to the sides, inside the cleaning area of windscreen wipers or outer mirrors not visible.	MiD MaD

3.2. Condition of Glass

3.2. CONDITION OF GLASS

Method of testing

1. Check the presence, condition and security of the windscreen, all side and rear windows, internal panes/partitioning and roof glazing.
2. Check that the windscreen is not damaged or discoloured beyond acceptable limits (see below).
3. Check that where the windscreen and all other glazing is made of glass it is marked as safety glass, e/E-marked or to an automotive standard as per Table 1.
4. Check that in the case of vehicles first registered on or after 1st January, 1986 the windscreen is made of laminated safety glass and marked as shown on pages 54-56 or to an equivalent standard as shown in Table 1 below.
5. Check that the driver's window operating mechanisms are functioning properly.

Notes

- If the glazing presented is not marked or is marked to a standard not listed below, it is the responsibility of the owner/presenter to provide documentary evidence that the glazing material is not likely, if fractured, to produce fragments capable of causing severe cuts.
- If a tester deems that the windscreen, internal panes/partitioning or front side windows are excessively tinted, the level of light transmission of the window should be tested using a calibrated light meter capable of measuring the amount of light transmitted through the windscreen and the side windows forward of the B pillar to an accuracy of $\pm 3\%$.
- Windscreen repairs are acceptable provided they do not effect the drivers view.
- It is the responsibility of the owner/presenter to provide proof of standards equivalency if a vehicle is presented with glass marked to another standard other than one shown in Table 1 on page.
- A vehicle with an emergency windscreen fitted, should fail under Reason for Failure 3.2(e).
- Reason for failure 3.2(e) applies to side and rear glass in respect of vehicles first registered on or after 1st July 1964.
- Light scratching which does not obscure the driver's view should be ignored. However, an area of concentrated scratching such as caused by the prolonged use of a defective wiper blade which obscures vision should be considered a reason for failure.
- Official stickers are permitted to encroach into zone B. These should be considered as a reason for failure only where they seriously restrict the drivers view to the front or the sides.
- Zone C includes "Opaque Obscuration" i.e. any area of the glazing preventing light transmission, including any screen-printed area, whether solid or dot-printed, but excluding any shade band.

3.2. CONDITION OF GLASS

CHECK ITEMS	REASONS FOR FAILURE	SEVERITY
<p>Check for:</p> <ul style="list-style-type: none"> a. Presence and security of windscreen. b. Visibility through windscreen. c. Windscreen damage / discolouration (outside cleaning area of windscreen wipers). d. Windscreen damage / discolouration (inside cleaning area of windscreen wipers). e. Automotive safety glass (windscreen). f. Windscreen laminated / marked to equivalent standard. g. Security (side and rear windows) h. Operation of opening mechanism (driver's window). i. Non glass windows (side, rear, roof glazing). j. Side / rear window damage (driver's view obstructed). k. Light transmission. 	<ul style="list-style-type: none"> (a). Windscreen missing. (b). Visibility through inside cleaning area of windscreen wipers heavily affected. (c). Windscreen is damaged or discoloured beyond acceptable limits (outside cleaning area of windscreen wipers). (d). Windscreen is damaged or discoloured beyond acceptable limits (inside cleaning area) of windscreen wipers affected or outer mirrors not visible. (e). In vehicles first registered after 1 July 1964 windscreen, side or rear glass is not marked as automotive safety glass. (f). In vehicle registered on or after 1 January 1986 windscreen is not marked as laminated or marked to an equivalent certified standard (see notes). (g). Windscreen or windows insecure. (h). Opening mechanism of driver's window not operating. (i). Non-glass windcreens, side, rear windows, internal panes/partitioning and roof glazing made of material that, if fractured is likely to produce fragments capable of causing severe cuts to a person. (j). Side or rear window so damaged that it obstructs the driver's view. (k). Glass in windscreen, internal panes/partitioning and front side windows located in a position requisite for driving has a light transmission level of less than 65%. 	<ul style="list-style-type: none"> MaD DD MaD MaD MaD MaD MaD MiD MiD MaD MaD

3.2. Condition of Glass

Table 1: Acceptable safety glass standards

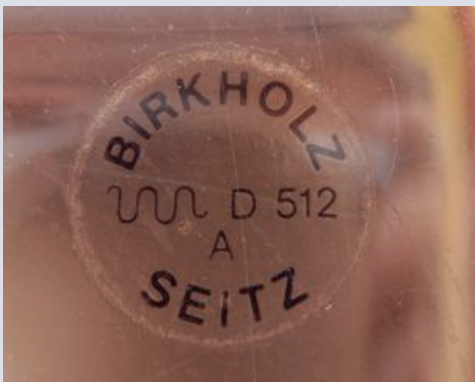
COUNTRY	SAFETY GLASS STANDARD
Australia:	AS/NZS 2080 AS/NZS 2080T
Canada:	CMVSS 205 (C2)
India:	IS2553 (Part 2) 1992 (Note 11)
Japan:	11-4-21 (window glass) JISR 3211
South Africa:	SABS 1191 / SABS 1193
UK:	BS AU 178 / BS 85 7-2 / BS 5282
USA:	FMVSS 205 (U) ANSI/SAE Z26.1-1996 (Section 7)
Germany:	<p>A three-period sine wave followed by the letter D. This is an older German type approval for automotive glazing. (See image below).</p>  <p>Glazing marked Birkholz, Seitz, Roxite, Para Press or Bonoplex. Glazing marked PMMA (polymethylmethacrylate) or PC (polycarbonate).</p>

3.2. Condition of Glass

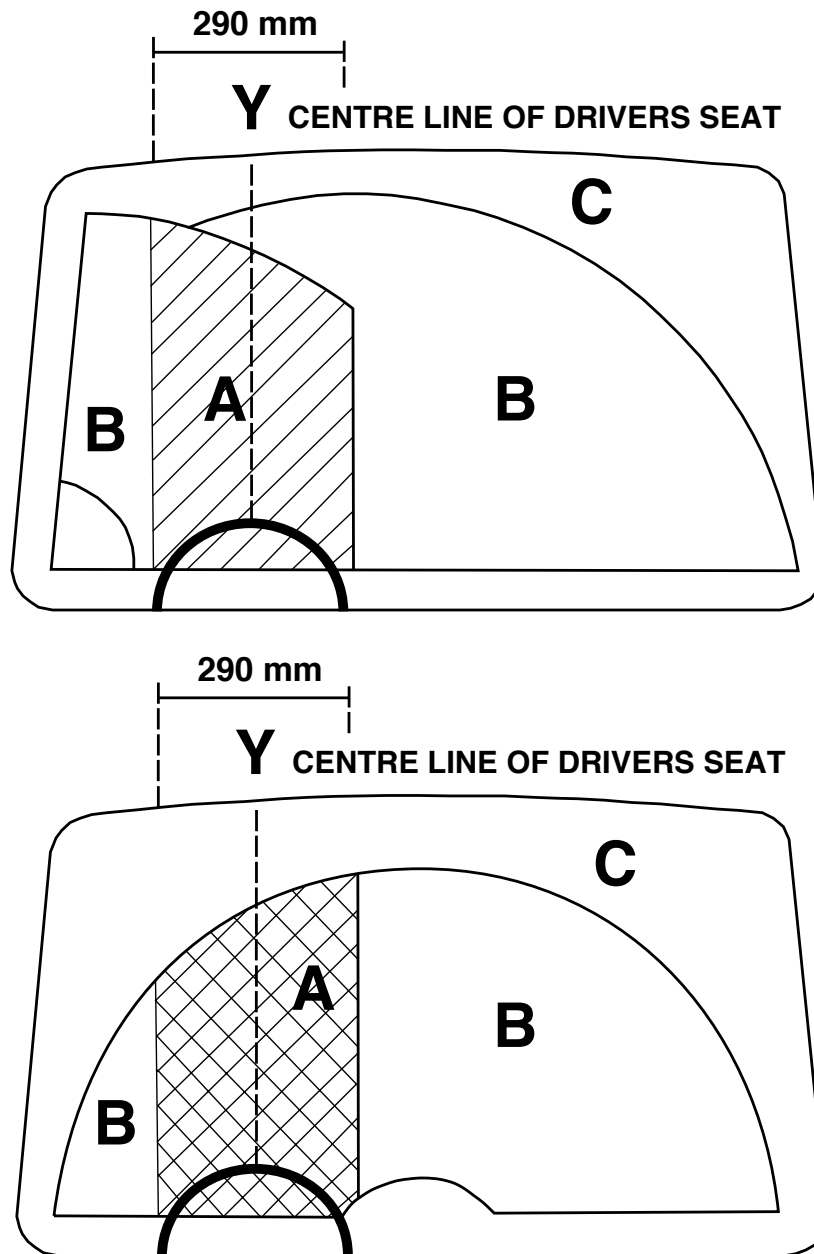

ACCEPTABLE LIMITS

- ZONE A; Damage that can be contained within a 10mm diameter circle (maximum of two defects provided they are more than 100mm apart).
- ZONE B; Damage that can be contained within a 20mm diameter circle or hairline cracks up to 30mm long (maximum of two defects provided they are more than 100mm apart).
- ZONE C; Damage is acceptable other than where it affects view to the front or damage which exposes the inner layer of a laminated screen, renders the screen insecure or interferes with any ADAS sensor/camera.

3.2. Condition of Glass

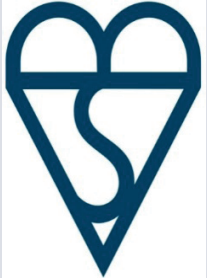
COUNTRY IN WHICH MARK ISSUES	APPROVED STANDARD MARKS
<p>Any country which has subscribed to the Agreement of the United Nations Economic Commission for Europe concerning the adopting of uniform conditions of approval and reciprocal recognition of approval for motor vehicle equipment and parts. Done at Geneva on 20th March, 1958.</p>	<p style="text-align: center;">II</p> <div style="text-align: center;">  </div> <p style="text-align: center;">43R**</p> <p>* This number varies and relates to the country which issued the approval. ** In association with the standard mark a serial number assigned by the issuing country is shown in this position.</p> <p>NOTE</p> <ul style="list-style-type: none"> The absence of II or III above or beside the approved standard mark indicates that the glass is not laminated.
<p>United Kingdom</p>	<div style="text-align: center;">  </div> <p>B.S. 857-2 or B.S. 5282 or B.S.AU 178</p> <p>NOTE</p> <ul style="list-style-type: none"> The B.S. must be accompanied by the word laminated or the letter L.WL or WLT The absence of these will indicate that the glass is not laminated.

Ordinary laminated glass windscreen	II e2*	001241 **
Ordinary laminated glass coated	II/P e2*	001242 **
Treated laminated glass windscreen	III e2*	001243 **
Glass-plastic windscreen	IV e1*	001244 **

* This number varies and relates to the country which issued the approval.

** In association with the standard mark a serial number assigned by the issuing country is shown in this position.

3.3. Rear-view Mirrors or Devices

3.3. REAR-VIEW MIRRORS OR DEVICES

Method of testing

1. Check the number and position of the mirrors or device(s) which afford the driver a view to the rear.
2. Check the condition of each mirror to see that the reflecting surface is not deteriorated or broken so as to impair the driver's view.
3. Check the security and condition of each mirror or device(s) mounting bracket.

Notes

- The test should only be applied to the rear view mirrors required.
- Indirect vision devices (cameras) may replace mirrors on some vehicles, with the view through to the rear displayed on a screen in the driver's cabin.
- There are three acceptable positions for rear view device(s): an exterior device that provides a view along the offside of the vehicle, an exterior device that provides a view along the nearside of the vehicle, a device which provides a view to the rear of the vehicle.

CHECK ITEMS	REASONS FOR FAILURE	SEVERITY
Check for:		
a. Presence.	(a). Interior rear view mirror, or where fitted as original equipment by the manufacturer, an external rear view mirror is missing.	MaD
b. Condition, operation and security.	(b). Reflecting surface of interior mirror, or where fitted as original equipment by the manufacturer, external rear view mirror is deteriorated or is broken so as to impair driver's view.	MaD
c. Presence.	(c). Mirror or device missing or not fitted according to the requirements ¹ (Fewer than two rear-view devices available).	MaD
d. Security.	(d). Mirror/device or mounting of any mirror is loose or slightly damaged.	MiD
e. Operation.	(e). Mirror or device inoperative, heavily damaged, loose or insecure.	MaD
f. Mirror adjustable.	(f). Mirror not adjustable.	MiD
g. External right hand mirror.	(g). Estate or hatch back vehicle not fitted with an exterior mirror on each side of the vehicle, except in the case of vehicles not fitted with these mirrors by the manufacturer.	MaD
h. Field of vision.	(h). Necessary field of vision not covered.	MaD

3.4. Windscreen wipers

3.4. WINDSCREEN WIPERS

Method of testing

1. Switch on the windscreen wipers and check that the wipers move at an appropriate speed over an arc of the windscreen glass which is sufficient to give the driver an adequate view of the road.
2. Check the condition of any visible components for the operation of the wipers. Check the wiper controls.
3. Check the condition of the wiper arms and blades. Check that the springs are not weak or broken on the wiper arms.
4. Check wiper linkage for wear.

Notes

- The above methods of testing only apply to the front windscreen wipers.
- Intermittent wiper speed is not a reason for failure if not operating.

CHECK ITEMS	REASONS FOR FAILURE	SEVERITY
Check for: a. Presence and condition (wiper arms and blades). b. Effective operation. c. Speed control (normal speed). d. Control operation. e. Linkage condition.	(a). A wiper arm or blade is missing, worn or defective. (b). Wiper arms and blades are operating such that the wiped area is less than sufficient to give the driver an adequate view. (c). Wipers are not operating at normal speed or not in accordance with the requirements ¹ . (d). Wiper control is not working, defective, insecurely mounted or missing. (e). Wiper linkage is broken, excessively worn or insecure.	MaD MaD MiD MaD MaD

3.5. Windscreen Washers

3.5. WINDSCREEN WASHERS

Method of testing

1. Switch on the windscreen washers and check for operation and leaks.

Notes

- Washers are to be considered as being fitted if there is any part of a washer system fitted.
- The above methods of testing only apply to the front windscreen washers.
- Where no washer is fitted or there is no fluid in the washer reservoir, check the function of the wipers and visually for defects on the blade that would fail effectiveness (reason (b)).

CHECK ITEMS	REASONS FOR FAILURE	SEVERITY
Check for: a. Correct operation. b. Non operation / leaks.	(a). Washers not operating adequately (lack of washing fluid but pump operating or water-jet misaligned). (b). Washers not working or leaking.	MiD MaD

3.6. Demisting System

3.6. DEMISTING SYSTEM

Method of testing

1. Check demisting system for operation.
2. Check the system directs air to the windscreen.

Notes

- The above methods of testing only apply to the demisting system for the front windscreen.

CHECK ITEMS	REASONS FOR FAILURE	SEVERITY
Check for: a. Correct operation. b. Correct placement.	(a). Demisting/ventilation system (fan) inoperative or obviously defective. (b). Demisting/ventilation system not directing towards windscreen.	MiD MiD

4. LAMPS, REFLECTORS AND ELECTRICAL EQUIPMENT

CONTENTS

4.1. HEADLAMPS	61	4.6. REVERSING LAMPS (WHERE FITTED)	78
4.1.1. CONDITION & OPERATION	61	4.6.1. CONDITION & OPERATION	78
4.1.2. ALIGNMENT	62	4.6.2. COMPLIANCE WITH REQUIREMENTS	79
4.1.3. SWITCHING	66	4.6.3. SWITCHING	79
4.1.4. COMPLIANCE WITH REQUIREMENTS	66	4.7. REAR REGISTRATION PLATE LAMP	80
4.1.5. LEVELLING DEVICES	67	4.7.1. CONDITION & OPERATION	80
4.1.6. CLEANING DEVICES	67	4.7.2. COMPLIANCE WITH REQUIREMENTS	80
4.2. FRONT AND REAR POSITION LAMPS, SIDE MARKER LAMPS AND DAYTIME RUNNING LAMPS	68	4.8. RETRO-REFLECTORS	81
4.2.1. CONDITION & OPERATION	68	4.8.1. CONDITION	81
4.2.2. SWITCHING	69	4.8.2. COMPLIANCE WITH REQUIREMENTS	82
4.2.3. COMPLIANCE WITH REQUIREMENTS	69	4.9. TELL TALES	82
4.3. STOP LAMPS	70	4.9.1. CONDITION AND OPERATION	82
4.3.1. CONDITION & OPERATION	70	4.9.2. COMPLIANCE WITH REQUIREMENTS	82
4.3.2. SWITCHING	71	4.10. ELECTRICAL CONNECTIONS BETWEEN TOWING VEHICLE AND TRAILER (TRAILER SOCKET).	83
4.3.3. COMPLIANCE WITH REQUIREMENTS	71	4.10. ELECTRICAL CONNECTIONS BETWEEN TOWING VEHICLE	83
4.4. DIRECTION INDICATOR AND HAZARD WARNING LAMPS	72	4.11. ELECTRICAL WIRING	84
4.4.1. CONDITION & OPERATION	72	4.11. ELECTRICAL WIRING	84
4.4.2. SWITCHING	73	4.12. NON OBLIGATORY LAMPS AND RETRO-REFLECTORS (AUXILIARY LAMPS)	85
4.4.3. COMPLIANCE WITH REQUIREMENTS	74	4.12. NON OBLIGATORY LAMPS AND RETRO-REFLECTORS (AUXILIARY LAMPS)	85
4.4.4. FLASHING FREQUENCY.	74	4.13. BATTERY(IES).	86
4.5. FRONT AND REAR FOG LAMPS	75		
4.5.1. CONDITION & OPERATION (WHERE FITTED)	75		
4.5.3. SWITCHING	76		
4.5.4. COMPLIANCE WITH REQUIREMENTS	76		

4. LAMPS, REFLECTORS AND ELECTRICAL EQUIPMENT

4.1. Headlamps

4.1.1. CONDITION & OPERATION

Method of testing

1. With the headlamps switched on main and dipped beam in turn, see that they each show as selected a light both of the same colour (white or yellow) of such intensity to illuminate sufficiently the road in front of the vehicle.
2. Check the presence, condition, colour and security of the headlamp glass and reflectors.
3. Check for the presence of water / moisture in the headlamp(s).
4. Check that where right hand dipping headlamps are fitted that these are masked/deflected to meet test pass criteria.
5. Check for defective light source(s) (in the case of LED's more than 50% not functioning is a reason for failure).
6. Check that where a High Intensity Discharge (HID) light source is fitted that it is compatible with the headlamp.

Notes

- Moisture / condensation in a lamp is not a reason for failure unless it obscures the illuminating surface of the lamp.
- Headlamps should consist of either two or four lamps, or one lamp in the case of an electric vehicle incapable of exceeding 40km/h (24mph).
- A HID light source may be recognised by the: light having a bluish tinge and/or taking a few seconds to reach full intensity, headlamp having an igniter module/inverter (ballast) behind the headlamp and/or having "DCR" marked on the lens.

Advisory Pass applies where there is a defective light source (multiple light sources or in the case of LED up to 50% not functioning).

CHECK ITEMS	REASONS FOR FAILURE	SEVERITY
Check for:		
a. Operation (dipped beams).	(a). Dipped beams not working simultaneously.	MaD
b. Operation (main beams).	(b). Main beams not working simultaneously.	MaD
c. Operation (main or dipped beams).	(c). Main or dipped beams not working.	MaD
d. Light intensity.	(d). Light intensity is not acceptable.	MaD
e. Presence and condition (reflecting material).	(e). Slightly defective projection system (reflector and lens).	MiD
f. Presence and condition (glass).	(f). Glass badly cracked or missing.	MaD
g. Presence and condition (reflecting material).	(g). Reflecting material damaged/discoloured or missing.	MaD
h. Presence (headlamp).	(h). Headlamp missing.	MaD
i. Security (headlamp).	(i). Headlamp is insecurely/incorrectly mounted	MaD
j. Water / moisture (headlamp).	(j). Headlamp contains water/moisture.	MaD
k. Colour (emitted light).	(k). All lamps not either white or yellow in colour.	MaD
l. Defective light source(s) (working).	(l). Single light/light sources; in the case of LED more than 50% not functioning, seriously affected visibility.	MaD
m. Compatibility (HID/LED bulb and headlamp).	(m). Light source and lamp not compatible.	MaD

4.1.2. ALIGNMENT

The headlamp aim test must be carried out on the certified level floor area within the test premises.

Method of testing

1. Check the tyre pressures and correct them if necessary.
2. Check the alignment of the headlamps by completing the following steps;
 - (a). Align the headlamp aim tester (HAT) perpendicular to the front of the vehicle at the recommended distance (as per the HAT manufacturer's specifications).
 - (b). Place the HAT at the centre of the vehicle and use the mirrors or laser to align the HAT perpendicular to the vehicle by locating two stable common points at opposite sides of the vehicle, such as strut mounting points or corners of the bonnet.
 - (c). Rotate the HAT until the fixed points are in line with the guide line.
 - (d). Check if the centre of the headlamp (or the centre of the bulb for headlamps with only one bulb fitted) is greater than or less than 850mm from the ground. The test requirements depend on the distance from the centre of the headlamp to the ground.
 - (e). Switch on dipped headlight and set the headlamp adjuster inside the vehicle to its highest setting. Move the HAT in front of each headlamp and take the readings of the gradient % of the highest intensity of the beam image relative to the plane on which the vehicle is standing.

Notes

- Headlamps fall into three categories as follows:
 - European Type Headlamp - checked on dip beam (see Figure 1 below for method of test);
 - British-American Type Headlamp - checked on dip beam (see Figure 2 below for method of test);
 - British-American Type Headlamp - checked on main beam (see Figure 3 below for method of test).
- Any headlamp levelling device should be in the 'O' position and suspension systems should be set in the normal road position.
- If a vehicle is presented with left hand drive headlamps and beam masks, the masks must be installed to ensure they effectively block any light projection above the 0% horizontal reference line. This would then show a pattern similar to a mirror image of Fig. 2 and can be checked as on that guide.
- On vehicles fitted with hydro pneumatic suspension, the engine must be idling during this test.

4.1.2. ALIGNMENT

CHECK ITEMS	REASONS FOR FAILURE	SEVERITY
<p>Check for:</p> <p>a. Alignment.</p> <p>b. Alignment.</p> <p>c. European type headlamp.</p> <p>d. British American Type Headlamp (checked on dip beam).</p> <p>e. British American Type Headlamp (checked on main beam).</p> <p>f. Horizontal aim of each headlamp on dipped beam using the electronic vehicle interface.</p>	<p>(a). Aim of a headlamp not within limits laid down in the requirements¹.</p> <p>(b). Headlamps are dipping to the right.</p> <p>(c). European type headlamps.</p> <ul style="list-style-type: none"> • For headlamps whose centre is not more than 850mm above the ground the horizontal cut off line does not lie between the -0.5% and -2% horizontal lines. • For headlamps whose centre is more than 850mm above the ground the horizontal cut off line does not lie between the -1.25% and -2.75% horizontal lines. • The junction of the 15 degree cut off and horizontal cut off line does not lie between the 0% and -2% vertical lines. <p>(d). British American Type Headlamp (checked on dip beam)</p> <ul style="list-style-type: none"> • The upper edge of the hot spot does not lie between the 0% and -2.75% horizontal lines. • The right hand edge of the hot spot does not lie between the 0% and -2% vertical lines. <p>(e). British American Type Headlamp (checked on main beam)</p> <ul style="list-style-type: none"> • For headlamps whose centre is not more than 850mm above the ground the hot spot centre does not lie between the 0% and -2% horizontal lines. • For headlamps whose centre is more than 850mm above the ground the hot spot centre does not lie between the 0% and - 2.75% horizontal lines. • The centre of the hot spot does not lie between the 0% and -2% vertical lines. <p>(f). System indicates failure via the electronic vehicle interface.</p>	<p>MaD</p> <p>MaD</p> <p>MaD</p> <p>MaD</p> <p>MaD</p> <p>MaD</p> <p>MaD</p> <p>MaD</p> <p>MaD</p>

Figure 1. European Type Headlamp – checked on Dipped Beam

The lens may be circular, rectangular or trapezoidal in shape. It will usually have a segment shaped pattern moulded into the glass.

It may be marked with a '2' and an arrow or a 'C' above either an 'E' or 'e'. On dipped beam it will produce a pattern similar to Fig. 1 below.

Check on dipped beam and determine that:

- (b). The junction of the 15° cut-off and horizontal cut-off lines lies between the 0% and -2% vertical lines.
- (c). The position of the horizontal cut-off line must lie between:
 - i. The -0.5% and -2.0% boundary lines shown on the screen in Red - for head lamps whose centre is not more than 850mm above the ground;
 - ii. The -1.25% and -2.75% boundary lines - shown on the screen in Blue - for headlamps whose centre is more than 850mm above the ground.

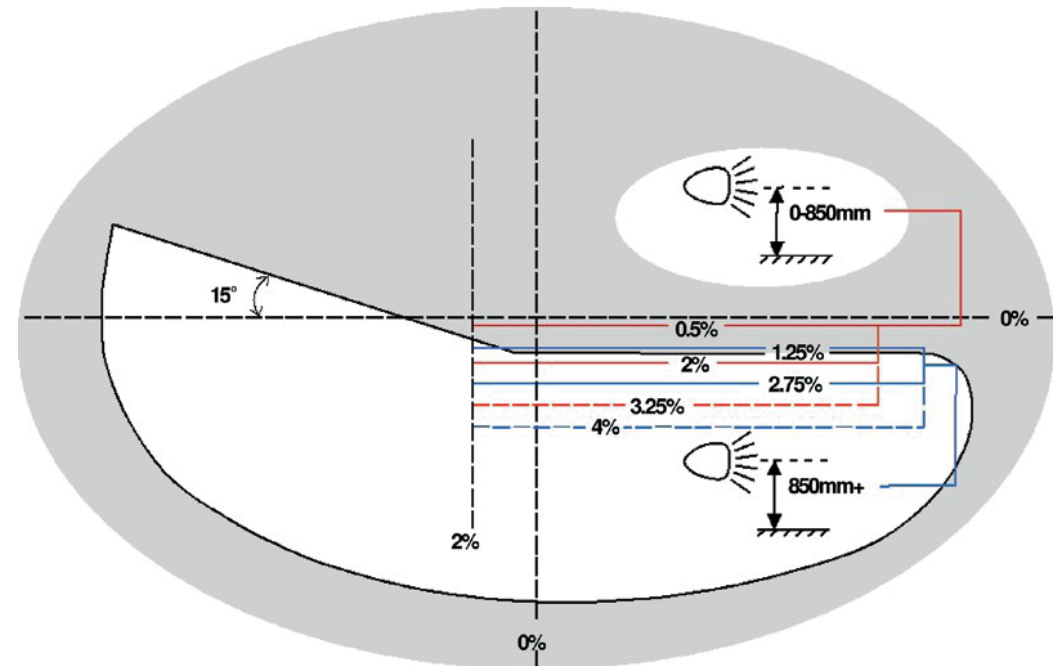

Figure 2 British-American Type Headlamp – checked on Dipped Beam

The lens is usually circular and of a sealed beam construction. It may be marked with an 'E' or a '2' and may also have an arrow. On dipped beam it will produce a pattern similar to Fig. 2 below.

Check on dipped beam and determine that:

- (a) The upper edge of the hot spot lies between the 0% and -2.75% horizontal lines shown on the screen;
- (b) The right hand edge of the hot spot lies between the 0% and -2% vertical line.

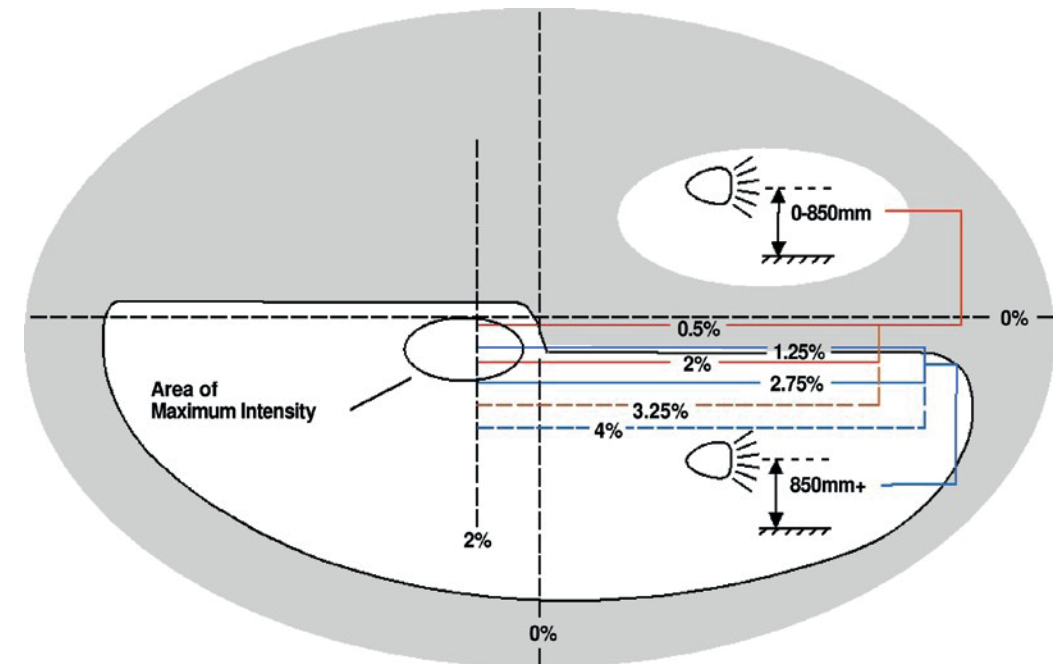

Figure 3 British-American Type Headlamp – checked on Main Beam

The lens of this type of headlamp is circular and likely to be of the sealed beam construction. It may be marked with a '1' and an arrow. It will not have a C above either an 'E' or e. The dipped beam pattern will not match either of the figures shown on the previous pages but the main beam will be similar to Fig. 3 below.

Check on main beam and determine that:-

The centre of the hot spot lies between the 0% and -2% vertical lines;

For headlamps whose centres is not more than 850mm above the ground, the hot spot centre lies between the 0% and -2% horizontal lines;

For headlamps whose centre is more than 850mm above the ground, the hot spot centre lies between the 0% and -2.75% horizontal lines.

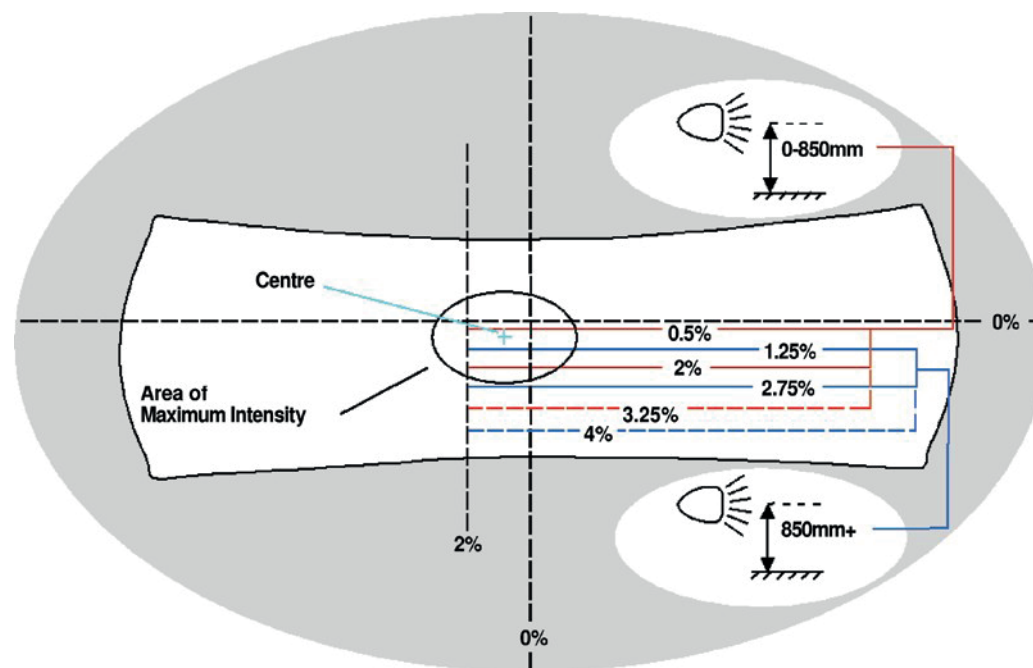

4.1.3. SWITCHING

Method of testing

1. Check the presence, security and operation of the headlamp and dip switch.

CHECK ITEMS	REASONS FOR FAILURE	SEVERITY
Check for: a. Operation (switch). b. Light intensity. c. Operation (device/switch). d. Operation (dip switch). e. Security (switch). f. Malfunction indicator.	(a). Switch does not operate in accordance with the requirements ¹ . (b). Maximum permitted light brightness to the front exceeded (where measured). (c). Function of control device/switch impaired or defective. (d). The dip or headlamp switch defective. (e). The dip or headlamp switch is insecurely mounted or missing. (f). System indicates failure via the electronic vehicle interface.	MiD MaD MaD MaD MaD MaD

4.1.4. COMPLIANCE WITH REQUIREMENTS

Method of testing

1. Check that the vehicle is fitted with obligatory headlamps, as follows:
 - a matched pair of main beam headlamps show light of the same emitted colour, position, brightness or marking.
 - a matched pair of dipped-beam headlamp show light of the same emitted colour, position, brightness or marking.
2. Check that there are no products on the lens or light source that reduce light brightness or change the emitted colour.
3. Check that the light source and lamp are compatible with each other.

CHECK ITEMS	REASONS FOR FAILURE	SEVERITY
Check for: a. Consistency (matched pairs). b. Condition (lens / light source). c. Compatibility (light source & lamp).	(a). Lamps do not show a light of the same emitted colour or brightness, position or markings not in accordance with the requirements ¹ . (b). Products on lens or light source which obviously reduce light brightness or change emitted colour. (c). Light source and lamp not compatible.	MaD MaD MaD

4.1.5. LEVELLING DEVICES

Method of testing

1. Check that headlamp levelling devices (where mandatory) are operating correctly and that manual headlamp levelling devices can be operated from the driver's seat.

CHECK ITEMS	REASONS FOR FAILURE	SEVERITY
Check for: a. Operation (levelling). b. Operation (manual levelling). c. Malfunction indicator.	(a). Where mandatory an automatic headlamp levelling device or manual headlamp levelling device not operating. (b). Manual headlamp levelling device cannot be operated from driver's seat. (c). System indicates failure via the electronic vehicle interface.	MaD MaD MaD

4.1.6. CLEANING DEVICES

Method of testing

1. Check for the presence and correct operation of a headlamp cleaning device where HID dipped beam headlamps are fitted.

Notes

- Headlamp cleaning devices are mandatory to be fitted with HID lamps with the exception of bulbs specified to produce 2000 lumens or less, retrofitted systems and vehicles which were not originally manufactured (type approved) for Europe.
- Any bulb producing more than 2000 lumens is officially categorised as HID.
- Bulbs specified to produce 2000 lumens or less are not required to have headlamp levelling or washer systems fitted.

CHECK ITEMS	REASONS FOR FAILURE	SEVERITY
Check for: a. Presence and operation.	(a). Where a headlamp cleaning device is mandatory (HID), the cleaning device is not present or operating correctly.	MaD

4.2. Front and rear position lamps, side marker lamps and daytime running lamps

4.2.1. CONDITION & OPERATION

Method of testing

The following checks apply to front and rear position lamps, side marker lamps (where fitted), end outline marker lamps (where fitted) and daytime running lamps (where fitted).

1. Check that there are two position lamps (side lamps) showing a white light fitted to the front of the vehicle and two position lamps (rear lamps) showing a red light fitted to the rear of the vehicle, one on each side of the centre line of the vehicle and clearly visible at a reasonable distance when illuminated.
2. Check for defective light sources, security of mounting, damage to any lens and for the presence of water/moisture.

Notes

- Two front position lamps must be fitted, one on each side and show a steady white light to the front (or yellow if incorporated in a yellow headlamp).
- Two rear position lamps must also be fitted, one on each side, showing a steady red light to the rear.
- When a side lamp is incorporated in a yellow headlamp, effectively producing a yellow side lamp, this is acceptable. In this case, the lamps on both sides of the vehicle must be the same colour.
- Moisture in a lamp is not a reason for failure unless it obscures the illuminating surface of the lamp.
- Where there are more than two rear position lamps, each must be in working order.
- For LED matrix lamps fitted, fail for reason 4.2.1 (a) or (i) as appropriate if less than 50% of LEDs are working in any single unit matrix.
- Daytime running lamps are not testable unless they replace the front position lamps. Where this is the case, they should dim when the position lamps are switched on and may extinguish when the headlamps are switched on.
- Where fitted the front and rear end outline marker lamps may be combined into one lamp.
- Repairs to lenses (e.g. lens repair tape etc.) must be assessed on their merits, considering security, colour, light output and durability.

Advisory Pass applies where there is a defective light source (multiple light sources or in the case of LED up to 50% not functioning).

CHECK ITEMS	REASONS FOR FAILURE	SEVERITY
Check for:		
a. Operation.	(a). Any lamp with a single light source not working or defective.	MaD
b. Presence and condition.	(b). Lens is missing, broken or badly cracked.	MaD
c. Position and security.	(c). A lamp is insecurely mounted.	MiD
d. Security (detachment likely).	(d). A lamp so insecurely mounted that there is a very serious risk of becoming detached.	MaD
e. Presence and visibility.	(e). A lamp is missing or is not clearly visible.	MaD
f. Dimensions and intensity.	(f). Lamps are not of the same dimensions and intensity.	MaD
g. Symmetrical fitment.	(g). Lamps are not fitted symmetrically.	MaD
h. Water / moisture.	(h). Contains water/moisture.	MiD
i. Intensity (side lamps).	(i). Defective light source, (single light source or in the case of LED less than 50% functioning.)	MaD
j. Colour (side lamps).	(j). Side marker lamp not correct colour.	MaD

4.2.2. SWITCHING

Method of testing

The following checks apply to front and rear position lamps, side marker lamps (where fitted), end outline marker lamps (where fitted) and daytime running lamps (where fitted).

1. Check the presence and security of the switch.
2. Check that the front and rear position lamps and side marker lamps (where fitted) illuminate with a single operation of the switch.
3. It must be possible to turn on the front and rear position lamps independent of the ignition switch.

CHECK ITEMS	REASONS FOR FAILURE	SEVERITY
Check for: a. Operation. b. Correct operation. c. Function (device/switch). d. Presence and security.	(a). For lights other than daytime running lights, switch does not operate in accordance with the requirements ¹ . (b). Rear position lamps and side marker lamps can be switched off when headlamps are on. (c). Function of control device/switch impaired or defective. (d). Switch insecurely mounted or missing.	MaD MaD MaD MaD

4.2.3. COMPLIANCE WITH REQUIREMENTS

Method of testing

1. Check that forward facing lamps do not emit a colour other than white and that a rearward facing lamp does not emit a colour other than red.
2. Check for products on lenses or the light source itself that reduce light, brightness or change the emitted colour.

CHECK ITEMS	REASONS FOR FAILURE	SEVERITY
Check for: a. Colour (lamps). b. Condition (lens / light source). c. Colour (front and rear). d. Compliance.	(a). A front lamp(s) showing a colour other than white or a rear lamp(s) showing a colour other than red. (b). Products on lens or light source which reduce light, brightness or change emitted colour. (c). Heavily reduced light brightness. (d). Lamp, emitted colour, position, brightness or marking not in accordance with the requirements ¹ .	MaD MiD MaD MiD

4.3. Stop lamps

4.3.1. CONDITION & OPERATION

Method of testing

With the ignition and rear lights switched on and the service brake applied, complete the following checks;

1. Check that the stop lamps are correctly positioned and secure.
2. Check that the lamps are working correctly, are not obscured, emit a steady red light and are not adversely affected by the operation of any other lamp.

Notes

- Moisture/ condensation in a lamp is not a reason for failure unless it obscures the illuminating surface of the lamp.
- For the third (high) brake lamp, reason for failure 4.3.1 (k) does not apply.
- Additional stop lamps (other than those fitted by the vehicle manufacturer) are not part of the test.
- LED matrix lamps should incur a fail for reason 4.3.1 (i) if less than 50% of LEDs are working in any single unit matrix.
- The precise position of obligatory lamps is not part of the test, but check visually that the lamps are at about the same height and the same distance from each side of the vehicle.
- Repairs to lenses (e.g. lens repair tape etc.) must be assessed on their merits, considering security, colour, light output and durability.

Advisory Pass applies where there is a defective light source (multiple light sources or in the case of LED up to 50% not functioning).

CHECK ITEMS	REASONS FOR FAILURE	SEVERITY
Check for:		
a. Operation (all lamps).	(a). All stop lamps or light sources not functioning.	DD
b. Condition (lens).	(b). Slightly defective lens (no influence on emitted light).	MiD
c. Security.	(c). Any lamp is insecurely mounted.	MiD
d. Security (detachment likely).	(d). A lamp so insecurely mounted that there is a very serious risk of becoming detached.	MaD
e. Presence and visibility.	(e). Any lamp is missing or not clearly visible.	MaD
f. Operation.	(f). A stop lamp is not working or defective but at least one is still functioning.	MaD
g. Presence and condition.	(g). Heavily defective lens, missing, broken or badly cracked (emitted light affected).	MaD
h. Water / moisture.	(h). Contains water/moisture.	MiD
i. Defective light source(s) (working).	(i). Defective light source, (single light source or in the case of LED less than 50% functioning).	MaD
j. Dimensions and power.	(j). Not of the same dimensions and power.	MaD
k. Symmetrical fitment.	(k). Incorrectly positioned, not symmetrically located.	MaD

4.3.2. SWITCHING

Method of testing

1. With the ignition and rear lights switched on and the brake pedal applied, check that the stop lamps illuminate.
2. Check that the stop lamps extinguish without delay once the brake pedal is released.

CHECK ITEMS	REASONS FOR FAILURE	SEVERITY
Check for: a. Operation. b. Operation (device/switch). c. Malfunction indicator. d. Emergency brake light functions e. Operation	(a). Delay in the operation of stop lamps or does not operate in accordance with the requirements ¹ . (b). Function of control device/switch impaired or defective. (c). System indicates failure via the electronic vehicle interface. (d). Emergency brake light functions fail to operate, or do not operate correctly. (e). No operation at all.	MaD MaD MaD MaD DD

4.3.3. COMPLIANCE WITH REQUIREMENTS

Method of testing

With the ignition and rear lights switched on and the brake pedal applied, complete the following checks:

1. Check that the stop lamps are brighter than the rear position lamps when illuminated and are red in colour.
2. Check that both stop lamps are of the same dimensions and light intensity.

Notes

- Requirements relating to dimensions and intensity do not apply to the third (high) brake lamp.

CHECK ITEMS	REASONS FOR FAILURE	SEVERITY
Check for: a. Intensity. b. Colour. c. Compliance. d. Colour (stop lamps).	(a). Any lamp is not brighter than tail lights. (b). Any lamp is not red in colour. (c). Lamps do not show a light of the same emitted colour or brightness, position or markings not in accordance with the requirements ¹ . (d). White light showing to the rear or heavily reduced light brightness.	MaD MaD MaD MaD

4.4. Direction indicator and hazard warning lamps

4.4.1. CONDITION & OPERATION

Method of testing

Operate the left and right direction indicators and hazard warning lamps in turn and complete the following checks;

1. Check that each indicator is working correctly, is clearly visible, is in good condition, is the correct colour and is securely mounted.
2. Check that hazard warning lights are working correctly by checking that they operate all the direction indicators simultaneously with the ignition switched both on and off.

Notes

- Checking the operation of hazard warning lights alone is not a substitute for checking the operation of directional indicators operation.
- Where “repeater” indicators are fitted these must be working.

Advisory Pass applies where there is a defective light source (multiple light sources or in the case of LED up to 50% not functioning).

CHECK ITEMS	REASONS FOR FAILURE	SEVERITY
Check for: a. Defective lens (slightly defective). b. Defective lens (heavily defective). c. Security. d. Security (risk of falling off). e. Water / moisture. f. Presence and visibility. g. Operation. h. Presence and condition (lens). i. Defective light source.	(a). Slightly defective lens (no influence on emitted light). (b). Heavily defective lens (emitted light affected). (c). Any indicator lamp is insecurely mounted. (d). An indicator lamp so insecurely mounted that there is a very serious risk of becoming detached. (e). Contains water or moisture. (f). Any indicator lamp is missing, not fitted symmetrically or is not clearly visible. (g). Any indicator lamp is not working or is faulty. (h). A lens is broken or is missing. (i). Defective light source, (single light source or in the case of LED less than 50% functioning).	MiD MaD MiD MaD MiD MaD MaD MaD MaD

4.4.2. SWITCHING

Method of testing

1. Check the presence, security and operation of the selector switch by operating the left and right direction indicators and hazard warning lamps in turn.

Notes

- An indicator switch that does not self-cancel is not a reason for failure.

CHECK ITEMS	REASONS FOR FAILURE	SEVERITY
Check for: a. Operation (switch). b. Presence and condition.	(a). Indicator switch is faulty or does not operate in accordance with the requirements ¹ . (b). Indicator switch not working or missing.	MiD MaD

4.4.3. COMPLIANCE WITH REQUIREMENTS

Method of testing

1. Check visually that every direction indicator emits amber light (other than vehicles pre July 1964).
2. Check visually that every direction indicator is of the same dimensions and power and are positioned correctly, symmetrically located and securely mounted.

Notes

- For vehicles registered before July 1964 front indicators may be white or amber in colour.
- For vehicles registered before July 1964 rear indicators may be red or amber in colour.
- An indicator lamp may not be amber in colour, this is acceptable provided the emitted light is amber in colour.

CHECK ITEMS	REASONS FOR FAILURE	SEVERITY
Check for: a. Compliance. b. Pre July 1964 (single indicator).	(a). Lamp, emitted colour, position, brightness or marking not in accordance with the requirements ¹ (not amber in colour). (b). Brightness, colour or marking not in accordance with the requirements ¹ .	MaD MaD

4.4.4. FLASHING FREQUENCY

Method of testing

1. Check that the indicators fitted to the vehicle flashing constantly between 60 and 120 flashes per minute (flashing type).

CHECK ITEMS	REASONS FOR FAILURE	SEVERITY
Check for: a. Flashing frequency	(a). Rate of flashing not in accordance with the requirements ¹ (not flashing constantly between 60 and 120 flashes per minute).	MiD

4.5. Front and Rear Fog Lamps

4.5.1. CONDITION & OPERATION (WHERE FITTED)

Method of testing

1. With the rear fog lamp(s) and front fog lamp(s) switched on check that the lamp(s); are securely fitted to the vehicle,
2. Check that the fog lamp(s) are working, are not obscured, are in good condition and are not adversely affected by the operation of any other lamp.
3. Check the presence and operation of the rear 'tell-tale'.
4. Where rear fog lamps are originally fitted and removed this is a reason for failure.

Notes

- Moisture / condensation in a lamp is not a reason for failure unless it obscures the illuminating surface of the lamp.
- Where a vehicle is originally fitted with only one fog lamp (to the centre or offside of the vehicle) this is acceptable i.e. it should not be failed for not having two rear fog lamps.
- Where front fog lamps are fitted they must be in working order and be tested as per the applicable methods of testing above.
- Some 'tell-tales' may be in the form of a coloured tag on a switch.
- Repairs to lenses (e.g. lens repair tape etc.) must be assessed on their merits, considering security, colour, light output and durability.

Advisory Pass applies where there is a defective light source (multiple light sources or in the case of LED up to 50% not functioning).

CHECK ITEMS	REASONS FOR FAILURE	SEVERITY
Check for:		
a. Condition.	(a). Slightly defective lens (no influence on emitted light).	MiD
b. Condition (light affected).	(b). Heavily defective lens (emitted light affected).	MaD
c. Security.	(c). A lamp not securely attached.	MiD
d. Security (detachment likely).	(d). A lamp so insecurely mounted that there is a very serious risk of becoming detached or dazzling oncoming traffic.	MaD
e. Position (front fog lamp).	(e). Front fog lamp is incorrectly positioned.	MaD
f. Presence and visibility (rear fog lamp).	(f). Rear fog lamp missing or not clearly visible.	MaD
g. Condition (rear lens).	(g). Rear fog lamp lens broken, missing or badly cracked.	MaD
h. Water / moisture.	(h). Front or rear fog lamp contains water/moisture.	MiD
i. Defective light source.	(i). Defective light source, (single light source or in the case of LED less than 50% functioning).	MaD

4.5.3. SWITCHING

Method of testing

With dipped head lamps and the ignition switched on,

1. Check that the front fog lamp(s) (where fitted) can be operated independently of the side lights.
2. Check that the rear fog lamp(s) switch works correctly.

CHECK ITEMS	REASONS FOR FAILURE	SEVERITY
Check for: a. Operation. b. Operation.	(a). Switch does not operate in accordance with the requirements ¹ . (b). Switch is not working or defective.	MiD MaD

4.5.4. COMPLIANCE WITH REQUIREMENTS

Method of testing

With the rear and front fog lamps (where fitted) turned on;

1. Check that;
 - (a). Front fog lamps (where fitted) are white or yellow in colour.
 - (b). Rear fog lamps are red in colour.
 - (c). Fog lamps are positioned correctly as per Figure 4 below and is of an acceptable intensity.

CHECK ITEMS	REASONS FOR FAILURE	SEVERITY
Check for: a. Colour (front fog lamp). b. Colour (rear fog lamp). c. Position, intensity and markings. d. Compliance with the requirements ¹ .	(a). Front fog lamp is not showing white or yellow light. (b). Rear fog lamp not red in colour. (c). Lamps do not show a light of the same emitted colour or brightness, position or markings not in accordance with the requirements ¹ . (d). System does not operate in accordance with the requirements ¹ .	MaD MaD MaD MaD

4.5.4 Compliance with requirements

Figure 4 Fog Lamp(s) – Positioning

Lamps, Reflectors and Electrical Equipment

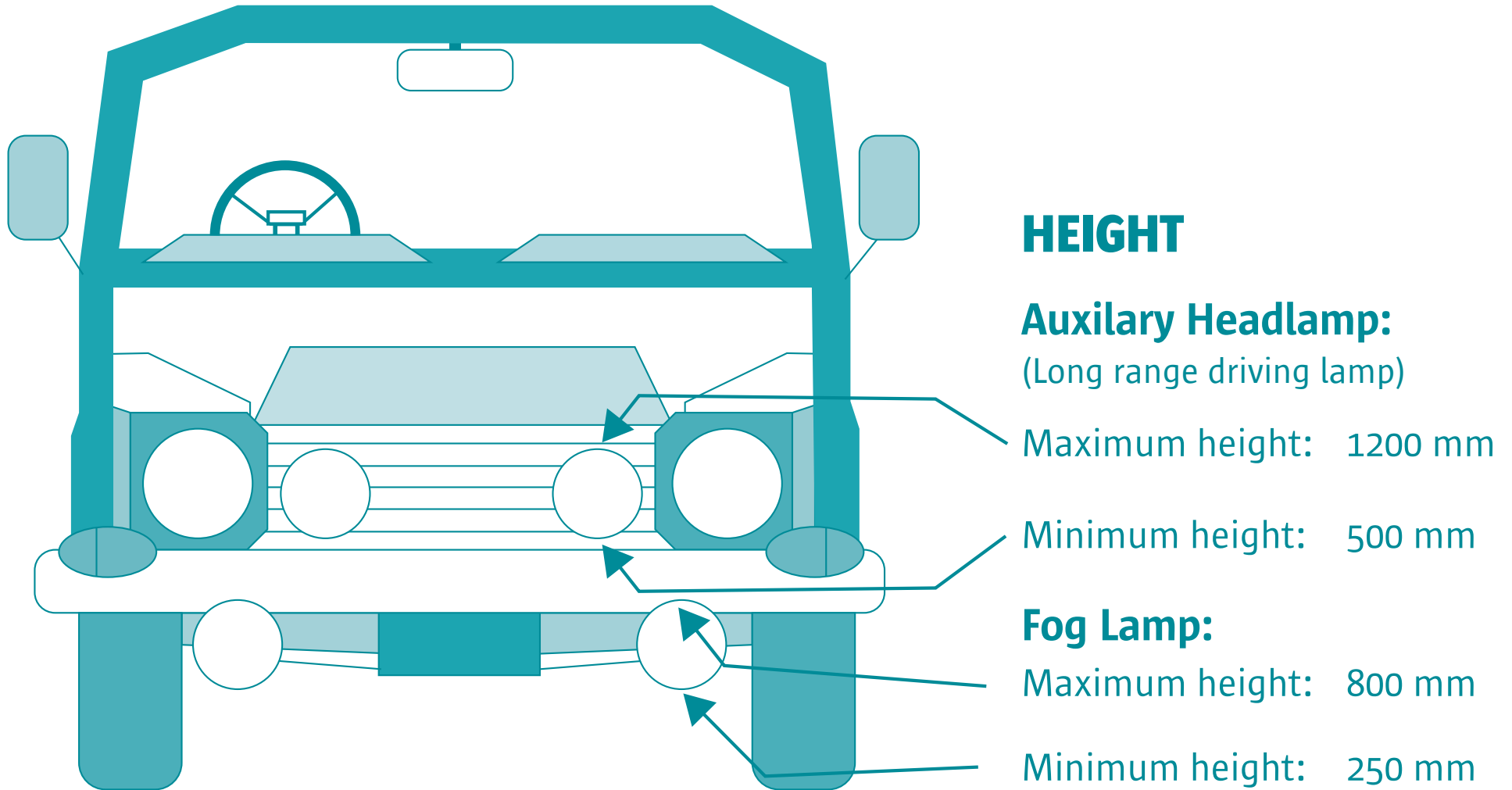

4.6. Reversing lamps (where fitted)

4.6.1. CONDITION & OPERATION

Method of testing

1. Check the presence, condition and security of the reverse lamp and lens.
2. With the ignition on and reverse gear engaged check that lamp is white in colour when operational.

Notes

- Moisture/ condensation in a lamp is not a reason for failure unless it obscures the illuminating surface of the lamp.

CHECK ITEMS	REASONS FOR FAILURE	SEVERITY
Check for: a. Condition and security (lamp). b. Presence and condition (lens). c. Security (detachment likely). d. Presence and visibility (lamp). e. Water / moisture. f. Colour.	(a). Defective light source/lens or lamp insecurely mounted. (b). Lens broken, missing or badly cracked. (c). Lamp so insecurely mounted that there is a very serious risk of it becoming detached. (d). Lamp missing or not clearly visible. (e). Contains water or moisture. (f). Lamp not white in colour when operational.	MiD MaD MaD MaD MiD MaD

4.6.2. COMPLIANCE WITH REQUIREMENTS

Method of testing

1. With the ignition on and reverse gear engaged check that lamp is white in colour when operational.

CHECK ITEMS	REASONS FOR FAILURE	SEVERITY
Check for: a. Compliance.	(a). Lamps do not show a light of the same emitted colour or brightness, position or markings not in accordance with the requirements ¹ .	MaD
b. Colour.	(b). Lamp not white in colour when operational.	MaD

4.6.3. SWITCHING

Method of testing

1. With the ignition switched on engage and disengage reverse gear in turn to check the operation of the reverse switch.

CHECK ITEMS	REASONS FOR FAILURE	SEVERITY
Check for: a. Operation.	(a). Reversing lamp can be switched on with gear not in reverse position.	MaD
b. Correct operation.	(b). Switch does not operate in accordance with the requirements ¹ .	MiD

4.7. Rear registration plate lamp

4.7.1. CONDITION & OPERATION

Method of testing

1. With the rear registration lamp(s) illuminated check that the lamp(s); are securely fitted to the vehicle, are not obscured and are in good condition.
2. Check that the rear registration lamp(s) are working, do not throw direct white light to the rear, and are not adversely affected by the operation of any other lamp.

Advisory Pass applies where there is a defective light source (multiple light sources or in the case of LED up to 50% not functioning).

CHECK ITEMS	REASONS FOR FAILURE	SEVERITY
Check for: a. Operation (direct white light to the rear). b. Defective light source (working). c. Defective light source. d. Presence and security. e. Security (detachment likely).	(a). Lamp showing direct (not reflected) white light to rear. (b). Defective light source, (single light source or in the case of LED less than 50% functioning). (c). Lamp lens is missing, broken or badly cracked. (d). Lamp is missing or is not securely attached. (e). Lamp is so insecurely mounted that there is a very serious risk of it becoming detached.	MiD MaD MiD MiD MaD

4.7.2. COMPLIANCE WITH REQUIREMENTS

Method of testing

1. With the rear registration lamp(s) illuminated check that the lamp(s) is white in colour when operational.

CHECK ITEMS	REASONS FOR FAILURE	SEVERITY
Check for: a. Colour.	(a). System does not operate in accordance with the requirements ¹ (Lamp is not white in colour when operational).	MiD

4.8. Retro-reflectors

4.8.1. CONDITION

Method of testing

Complete the following checks for rear reflectors;

1. Check that two red reflectors are fitted symmetrically to the rear of the vehicle.
2. Check that each reflector is secure, complete and operates in an effective manner.

Complete the following checks for side reflectors (if fitted):

1. Check that side reflectors (if fitted), are amber in colour.

Notes

- The rearmost side retro-reflector can be red. This applies in cases where it is part of a multifunctional lamp.
- Where more than 50% of a rear reflector is damaged or discoloured this is considered a reason for failure.

CHECK ITEMS	REASONS FOR FAILURE	SEVERITY
<p>Check for:</p> <ul style="list-style-type: none"> a. Condition. b. Security. c. Security (detachment likely). d. Presence. e. Size and appearance. f. Symmetrical fitment. 	<ul style="list-style-type: none"> (a). A rear reflector is so damaged that effectiveness is seriously reduced. (b). A rear reflector is insecurely mounted. (c). A rear reflector is so insecurely mounted that it is likely to fall off. (d). One or both rear reflectors are missing. (e). Rear reflectors are not matching in size and appearance. (f). Rear reflectors are not fitted symmetrically. 	<ul style="list-style-type: none"> MaD MiD MaD MaD MaD MiD

4.8. Retro-reflectors

4.8.2 COMPLIANCE WITH REQUIREMENTS

Method of testing

1. Check that a rear reflector is red in colour and that a side reflector (where fitted) is amber in colour.

CHECK ITEMS	REASONS FOR FAILURE	SEVERITY
Check for: a. Compliance. b. Colour.	(a). Device, reflected colour or position not in accordance with the requirements ¹ . (b). Missing or reflecting red colour to the front or white colour to the rear.	MiD MaD

4.9 Tell Tales

4.9.1 CONDITION AND OPERATION

Method of testing

1. Switch on the main beam headlamp and check that the main beam warning light is working correctly.
2. Turn on the direction indicators (left and right) and rear fog lamps in turn, checking that the tell tales for each function correctly.
3. Indicator tell tales may be visual or auditory or both.

CHECK ITEMS	REASONS FOR FAILURE	SEVERITY
Check for: a. Operation (indicator). b. Operation (main beam and rear fog warning lights).	(a). Indicator tell-tale is not working or is faulty. (b). Tell-tale not operating for main beam headlamp or rear fog lamp.	MiD MaD

4.9.2 COMPLIANCE WITH REQUIREMENTS

CHECK ITEMS	REASONS FOR FAILURE	SEVERITY
Check for: a. Compliance.	(a). Not in accordance with the requirements ¹ .	MiD

4.10. Electrical connections between towing vehicle and trailer (trailer socket)

4.10. ELECTRICAL CONNECTIONS BETWEEN TOWING VEHICLE

Method of testing

In cases where a towing coupling is fitted to a vehicle carry out the following checks:

1. Check trailer electrical sockets (where fitted) for; security, damage or deteriorated insulation.
2. Check the outputs from socket using appropriate equipment (only applies to brake, indicator and rear position lights).

Notes

- Some electrical sockets are hidden behind an access panel in the bumper or bodywork. Unless requiring the use of tools or specialist equipment, these panels must be removed to facilitate the inspection of the socket.
- A trailer electrical socket with a defective or missing cover flap that incorporates a lug and spring to hold the plug in place is not a reason for failure.
- Reason for failure (e) may only be selected when the outputs were checked using appropriate equipment (Light board or trailer socket tester).
- It is not always possible to check the outputs on the electrical socket on some vehicles using a dedicated trailer LED light tester. There are occasions where some LED light tester devices may not work as there isn't enough resistance for the control unit to recognise and work the LED's. The outputs on these vehicles should be checked using a standard trailer board with sufficient load resistance.

CHECK ITEMS	REASONS FOR FAILURE	SEVERITY
Check for: a. Security. b. Security (detachment likely). c. Condition. d. Condition (failure imminent). e. Operation (electrical connections).	(a). Socket/components not securely attached. (b). Socket/components so insecurely mounted that it is likely to fall off. (c). Damaged or deteriorated insulation. (d). Damaged or deteriorated insulation that it's likely to cause a short-circuit fault. (e). Trailer or towing vehicle electrical connections not functioning correctly (Incorrect or no outputs from socket).	MiD MaD MiD MaD MaD

4.11. Electrical wiring

4.11. ELECTRICAL WIRING

Method of testing

1. Visually check all visible electrical wiring, connections and components for condition, security and position.
2. Check for damage to insulation or deterioration to the extent that bare wiring or connectors are exposed (in the case of fully electric or Hybrid Electric vehicles care should be taken as per note below).
3. Check the positioning of wires and connections so that they are unlikely to be chafed or damaged by heat or fouled by moving parts.
4. Check for the use of unsuitable wiring/electrical connections e.g. household wiring/bell wiring etc.
5. Check where possible that after-market items with the exceptions of anti-theft systems and light failure indicators are wired through ignition switch or a fuse.
6. Check for the presence and condition of the ignition switch.

Notes

- When checking the condition and security of the wiring, care needs to be taken when inspecting the high voltage systems of fully electric or Hybrid Electric vehicles. These high voltage wires are colour coded orange.
- Additional care should be taken when testing electric and hybrid vehicles as there may be high voltage present at any one of several points around the vehicle, including storage capacitors and batteries.
- On hybrid vehicles, the engine may start without warning when electrical equipment is operated or if the battery voltage drops.
- There is no need to remove destination box panels, as a matter of course. The inspection requires a check on all visible wiring for condition, position and security. The test is generally limited to those parts which can be seen without dismantling and is based on the assumption that panels will only be removed where it is not possible to inspect safety critical items. It wouldn't normally be considered that this would apply to wiring contained in destination box panels unless there was reason to suspect seriously defective wiring.

CHECK ITEMS	REASONS FOR FAILURE	SEVERITY
Check for:		
a. Condition.	(a). Wiring/insulation deteriorated likely to cause a short-circuit fault.	MaD
b. Condition (safety critical).	(b). Wiring extremely deteriorated (relevant parts for braking, steering).	DD
c. Position (control affected).	(c). Wiring is liable to interfere with the driver's control of the vehicle.	MaD
d. Security and condition (electrical wiring).	(d). Slightly deteriorated or insecure wiring/insulation.	MiD
e. Security (connections).	(e). Fixings loose, touching sharp edges, connectors likely to be disconnected.	MaD
f. Fouling.	(f). Wiring likely to touch hot parts, rotating parts or the ground, connectors disconnected (relevant parts for braking, steering).	DD
g. After market items.	(g). After-market items with the exceptions of anti-theft systems, taxi signs and light failure indicators not being wired through ignition switch or a fuse.	MaD
h. Suitability (Connections / wiring).	(h). Use of unsuitable wiring/electrical connections, e.g. household wiring/bell wiring etc.	MaD
i. Ignition switch.	(i). Ignition switch is missing or faulty.	MaD
j. Condition.	(j). Damaged or deteriorated insulation, imminent risk of fire, formation of sparks.	DD

4.12. Non obligatory lamps and retro-reflectors (AUXILIARY LAMPS)

4.12. NON OBLIGATORY LAMPS AND RETRO-REFLECTORS (AUXILIARY LAMPS)

Method of testing

1. Check that each auxiliary lamp fitted is securely fixed to the vehicle.
2. Check that the switching mechanism is functioning correctly and where auxiliary lamps are set in the head lamp main beam position, they are extinguished when the headlamp dipped beams are brought into operation.
3. Check that any auxiliary lamp fitted is showing white or yellow light to the front and red light to the rear.

Notes

- Where auxiliary lamps are found to be inoperative, this should not be considered a reason for failure.

CHECK ITEMS	REASONS FOR FAILURE	SEVERITY
Check for: a. Fitment. b. Security. c. Security (detachment likely). d. Operation (independent of side light). e. Colour. f. Colour (white light to the rear). g. Operation (with main beam). h. Intensity.	(a). A lamp/retro-reflector fitted not in accordance with the requirements ¹ . Emitting/reflecting red light to the front or white light to the rear. (b). An auxiliary lamp is insecurely mounted. (c). An auxiliary lamp is so insecurely mounted that there is a very serious risk of becoming detached. (d). Lamp operation not in accordance with the requirements ¹ (auxiliary lamp switch is defective or does not operate independently of side light). (e). An auxiliary lamp is not showing white or yellow light to the front. (f). An auxiliary lamp is showing white light to the rear. (g). An auxiliary lamp is set in main beam position and does not extinguish when dipped beams are brought into operation. (h). Number of headlights simultaneously operating exceeding permitted light brightness (where measured).	MaD MiD MaD MaD MaD MaD MaD MaD

5. AXLES, WHEELS, TYRES AND SUSPENSION

CONTENTS

5.1. AXLES88
5.1.1. AXLES	88
5.1.2. STUB AXLES	89
5.1.3. WHEEL BEARINGS.	90
5.2. WHEELS AND TYRES91
5.2.1. ROAD WHEEL HUB	91
5.2.2. WHEELS	92
5.2.3. TYRES	93
5.3. SUSPENSION SYSTEM99
5.3.1. SPRING (COIL/LEAF), STABILISER AND TORSION BAR.	99
5.3.2. SHOCK ABSORBER(S)	102
5.3.2.1. EFFICIENCY TESTING OF DAMPING	102
5.3.3. TORQUE TUBES, RADIUS ARMS, WISHBONES AND SUSPENSION ARMS	104
5.3.4. SUSPENSION JOINTS	105
5.3.5. AIR SUSPENSION (HYDROLASTIC, HYDROGAS, HYDRO PNEUMATIC SUSPENSION & BONDED SUSPENSION UNITS).	106

5. AXLES, WHEELS, TYRES AND SUSPENSION

5.1. Axles

5.1.1. AXLES

Method of testing

1. Position the vehicle on a raised lift with the steered axle aligned over the wheel play detector plates with the brakes applied. Using the wheel play detectors, check the steering and axle attachment from the point it is secured to the chassis, to the point where the steering arms are secured to their fixings.
2. Check axle beams for damage, distortion or excessive corrosion.
3. Examine if there has been an unsafe repair or modification carried out.

CHECK ITEMS	REASONS FOR FAILURE	SEVERITY
Check for: a. Axle for cracks or deformation. b. Axle security. c. Axle security. d. Axle positioning. e. Modifications. f. Modifications. g. Axle mounting for wear and security.	(a). Axle fractured or deformed. (b). Axle fixing to vehicle insecure. (c). Axle stability impaired, functionality affected: Extensive movement relative to its fixtures. (d). Axle is obviously out of line. (e). Unsafe modification ² . (f). Unsafe modification ² that stability is impaired, functionality affected, insufficient clearance to other vehicle parts or to the ground. (g). Mounting bushes, bearing or bearing carrier, shafts, ball joints, obviously loose, worn or insecure.	DD MaD DD MaD MaD DD MaD

5.1.2. STUB AXLES

Method of testing

With steered wheels off the ground (using the vehicle manufacturer's recommended jacking points);

1. Check for excessive wear between the axle beam and the stub axle/kingpin whilst each wheel in turn is rocked with a bar, (approximately one metre long) one end inserted in the wheel disc and the other end lifted.
2. Check for excessive upward movement of the stub axle, whilst each wheel in turn is lifted with a bar placed underneath it.
3. Examine visible parts of the stub axle for condition and security and where possible examine the king pin retaining device.

Notes

- Kingpin(s) should be considered excessively worn where there is 3mm (or greater) play on 14" wheel rim, others pro-rata.
- Lift between a stub axle and axle beam should be considered excessive where there is 1.6mm (or greater) for a hive type and 1mm for other types.

CHECK ITEMS	REASONS FOR FAILURE	SEVERITY
Check for: a. Stub axles for cracks or deformation. b. Swivel pin and/or bushes/bearings for wear. c. Security of stub axle components. d. Movement between stub axle and axle beam. e. Movement between stub axle and axle beam. f. Kingpin security. g. Stub axle pin security. h. Retaining device for presence, wear and fractures.	(a). Stub axle fractured/damaged or bent. (b). Excessive wear in the swivel pin and/or bushes/bearings. (c). A component is insecure - Likelihood of loosening; directional stability impaired. (d). Excessive movement between stub axle and axle beam (Hive type 1.6mm, others 1mm). (e). Excessive movement between stub axle and axle beam that directional stability is impaired. (f). Stub axle pin loose in axle. (g). Stub axle pin so loose in axle that directional stability is impaired. (h). Kingpin retaining or locking device absent, insecure, worn or broken.	DD MaD DD MaD DD MaD DD MaD

5.1.3. WHEEL BEARINGS

Method of testing

With wheels off the ground (using the vehicle manufacturer's recommended jacking points);

1. Check for play at the wheel bearing whilst each wheel in turn is rocked.
2. Check for any roughness or harshness in the bearings by spinning each wheel rapidly and listening.

Notes

- The vehicle should be failed if a distinctive rumble or growl is heard that indicates the bearing is worn or damaged.
- It may be necessary where a vehicle is fitted with ABS/EBS that the wheel bearings should not be checked while the ignition switch is turned on as this can affect the ABS/EBS warning light.

CHECK ITEMS	REASONS FOR FAILURE	SEVERITY
Check: a. Wheel bearing(s) for play. b. Wheel bearing(s) for play. c. Wheel bearing(s) condition. d. Wheel bearing(s) condition. e. Wheel bearing(s) condition.	(a). Excessive play in a wheel bearing. (b). Excessive play in a wheel bearing that directional stability is impaired. (c). Wheel bearing too tight or jammed. (d). Wheel bearing is so tight that there is a danger of overheating or seizing. (e). Bearing(s) or hub are worn or damaged.	MaD DD DD DD MaD

5.2. Wheels and Tyres

5.2.1. ROAD WHEEL HUB

(This inspection applies to all road wheels and hubs apart from spare wheels).

Method of testing

1. Check that the hub is not worn or damaged and that the hub spigot makes sufficient contact with the wheel rim.
2. Check where twin wheels are fitted that the spigots extend to the outer wheel.
3. Check wheel nuts and studs for presence, security and condition.

Notes

- It is not always possible to see the complete road wheels on a vehicle from ground level, especially on vehicles where the body shrouds part of the wheels. In such cases the vehicle should be moved to expose the hidden parts of wheels or the examination should be completed from a position under the vehicle.
- Some wheel nut studs do not protrude all the way through the wheel nut this is acceptable provided there is no sign of insecurity.

CHECK ITEMS	REASONS FOR FAILURE	SEVERITY
Check: a. Studs or nuts for presence and security. b. Studs and nuts condition. c. Stud hole for elongation. d. Studs or nuts for damage. e. Stud or nut fitment. f. Studs or nuts compatibility. g. Hub for damage and wear. h. Hub damage and wear.	(a). Any wheel nuts or studs missing or loose. (b). Any stud or nut is in such a condition that there is an obvious danger that the wheel(s) will come loose. (c). Any stud hole is elongated or damaged. (d). Any studs or nuts are damaged or threads stripped or crossed. (e). Any wheel nut is incorrectly fitted. (f). An incorrect wheel nut is fitted. (g). Hub worn or damaged. (h). Hub worn or damaged in such a way that secure fixing of wheels is affected.	MaD DD MaD MaD MaD MaD MaD DD

5.2. Wheels and Tyres

5.2.2. WHEELS

Method of testing

1. Check each part of the road wheel, paying particular attention to whether there is any: fractures, distortion, wear, defective weld/repairs or incompatibility.

Notes

- Where wheel embellishers/ wheel covers are fitted or where an owner refuses to allow the wheel covers of the vehicle to be removed, the vehicle should be refused a certificate on the basis that the wheel nuts have not been inspected, reason for failure (h) below shall apply.

CHECK ITEMS	REASONS FOR FAILURE	SEVERITY
Check for: a. Cracks, fractures and defective weld/repair. b. Distortion. c. Distortion. d. Fitment/compatibility. e. Damage. f. The nominal size of the wheel to another on the same axle. g. Spoke damage. h. Wheel embellishers or hub caps.	(a). Any crack, fractures or defective weld present in a wheel. (b). Wheel badly distorted (more than 13mm (1/2") askew or buckled) or worn. (c). Wheel so badly distorted that secure fixing to hub is affected or the secure fixing of the tyre is affected. (d). A wheel is incorrectly fitted - wheel size, technical design, compatibility or type not in accordance with the requirements ¹ and affecting road safety. (e). A wheel is damaged such that tyre damage or seal damage can occur. (f). Different size wheels are fitted on the same axle. (g). Any spoke or other wheel component is in such a condition that there is a danger of failure. (h). Wheel embellishers or wheel covers not removed.	DD MaD DD MaD MaD MaD MaD MiD

5.2. Wheels and Tyres

5.2.3. TYRES

(This inspection applies to all tyres fitted to the vehicle apart from spare tyres).

Tyre Condition

Method of testing

Check each tyre fitted to the vehicle:

1. Check whether the tyre tread appears to be regrooved (tyres designed for recutting or regrooving will normally be marked as regroovable or with the symbol “U”).
2. Check visually each tyre is not seriously underinflated and that it is correctly seated on the rim.
3. Check each tyre for perished rubber, cracks or breaks in the fabric, any lumps or bulges, any exposure of the ply or cord structure. A tyre that has any cut greater than 25 mm in length or 10% of section width, deep enough to reach the ply or cords is a reason for failure.
4. Check each valve stem for damage, distortion or chafing.
5. Check for any inappropriate tyre repairs.
6. Check each tyre for fouling on any part of the vehicle or protruding beyond bodywork.
7. For vehicles first registered on or after **1 January 2015** which are fitted with a tyre pressure monitoring system (TPMS), check that:
 - a. the system is not obviously inoperative.
 - b. the warning lamp does not indicate a system malfunction.

Notes

- It will not always be possible to see the complete tyre from ground level, especially on twin wheels and on vehicles where the body shrouds part of the tyres. Any tyre or wheel examination must be performed with the vehicle raised on the lift to ensure that all parts of the wheel and tyre can be examined thoroughly.
- Examination is confined to tyres fitted to the road wheels. If, however, any defect on a tyre carried on a spare wheel is seen, the driver should be advised.
- When checking any tyre that appears to have been recut, it must be determined whether it has been recut to the manufacturer’s recut tread pattern. It can be difficult to identify tyres which have been skilfully recut, but extra care should be taken to check for any exposure of the ply or cord at the bottom of the grooves.
- The fitment of a plug to the side wall of a tyre is considered an inappropriate repair.
- TPMS warning lamps generally illuminate and go off again when the ignition is switched on. In cases where one or more tyre pressures are low, the lamp will remain illuminated indicating a problem. In the event of a system malfunction the lamp will remain on. Vehicles must only be rejected if it is clear that the lamp indicates a system malfunction.
- Inappropriate tyre repairs includes the use of a repair plug outside of the central three-quarters tread area. Please refer to page 97 figure 1.

Advisory Pass applies where the date of manufacture is obvious on the tyre, a tyre is older than six years.

Advisory Pass applies where the tyre pressure monitoring system (TPMS) is malfunctioning in a vehicle first registered before 1 January 2015.

5.2. Wheels and Tyres

5.2.3. TYRES

Tyre Specification

Method of testing

1. Check each tyre to ensure that its speed rating is appropriate for the maximum legal speed permitted for the vehicle (see table on page 96).
2. Check each tyre to ensure that the tyre load index rating for a single fitment tyre is not less than 50% (or for a twin fitment tyre is not less than 25%) of the design axle weight.
3. Check all the tyres fitted and note the type of structure (radial or cross-ply) and the nominal size of tyres.
4. Check all tyres on the same axle must be of the same structure and nominal size.
5. Check that each tyre fitted to the vehicle has an E-mark or e-mark.
6. Check that any tyre is not incorrectly matched with the wheel.
7. Check each tyre to ensure that the tyre use marking is appropriate for the type of axle or vehicle to which it is fitted. For example tyres marked “TRAILER USE ONLY” or “NOT FOR HIGHWAY USE” should not be fitted.

Notes

- Tyres on an axle may be of different structures and nominal sizes to those on another axle with the following exceptions:
 - All tyres on all steered axles must have the same structure.
 - All tyres on all driven axles must have the same structure.
 - On a two axle motor vehicle where each axle is fitted with single wheels, then all the tyres must be of the same structure, otherwise then the only tyre combination that is allowed is cross-ply in the front and radial at the rear. This does not apply to an axle on which wide single tyres with a road contact width of more than 300mm are fitted.
- The maximum permissible axle Load for normal use can be found in the tyre load data tables made available by the RSA. The Load Index (LI) may consist of one or two numbers e.g. 90 or 104/102.
- Unless marked otherwise, “standard” car tyres have a nominal aspect ratio of 82%. Some tyres have an aspect ratio of 80%. These have “/80” included in their size marking e.g. 165/80 R1 3. Tyres with aspect ratios of 80% and 82% are almost identical in size and can be safely mixed in any configuration on a vehicle. Where this is done, Reason for Failure (b) does not apply.

5.2. Wheels and Tyres

5.2.3. TYRES

Tyre Tread

Method of testing

1. Check all tyres with a tyre tread depth gauge, that the central three-quarters of the tread pattern has a depth of at least 1.6 millimetres around the full circumference of the tyre.

Notes

- The tread pattern means the combination of plain surfaces and groves extending across the breadth of the tread but excludes any tread wear indicators or features which are designed to wear out substantially before the rest of the pattern under normal conditions of use. Where the pattern is interrupted by tread wear indicators but has at least 1.6 mm overall tread depth the tyre concerned should not be failed for inadequate tread-depth.
- Any tyre or wheel examination must be performed with the vehicle raised on the lift to ensure that all parts of the wheel and tyre can be examined thoroughly.
- The original tread pattern means:
 - On a re-treaded tyre the tread pattern immediately after the tyre was retreaded.
 - On a recut tyre the manufacturer's recut tread pattern.
 - On a partly recut tyre, the part which has been recut the manufacturer's recut tread pattern, on the other part the tread pattern when new.
 - On any other tyre the tread pattern of the tyre when new.
- The following should be disregarded when deciding which grooves need to be checked in regard to the "original tread pattern".
 - Grooves which wear out before the main grooves are worn.
 - Other minor features such as sipes, small lateral extensions to the circumferential grooves and minor lateral grooving on the shoulders.

Advisory Pass applies where tyre tread depth is less than 3 mm (but more than 1.6 mm).

5.2.3. TYRES

CHECK ITEMS	REASONS FOR FAILURE	SEVERITY
Check for: a. Load capacity b. The nominal size of the tyre to another on the same axle. c. Tyre structure compatibility. d. Speed rating. e. Space saver fitment f. Fouling and protrusion. g. Compatibility. h. Directional and asymmetric. i. Tyre marking. j. Cut(s) and damage. k. Exposed ply or cords. l. Tread depth. m. Fouling on any part of the vehicle. n. Fouling on any part of the vehicle. o. Re-grooving requirements. p. Re-grooving. q. Inflation. r. Correct seating.	(a). Insufficient load capacity (Tyre load index rating for a single tyre is less than 50% of the design axle weight). (b). Tyres fitted to the same axle are not of the same size, aspect ratio or type (i.e. cross ply or radial, ply run flat, winter or summer). (c). Radial ply tyres are fitted to the front wheels but not to the rear wheels. (d). Speed rating of tyres cannot be determined on inspection or is insufficient for maximum legal speed limit. (e). A space saving tyre is fitted on an axle. (f). Tyre protrudes beyond bodywork or touches other fixed vehicle parts impairing safe driving. (g). Tyre is not fit for purpose. (h). Any tyre fitted in the incorrect direction (directional tyres) or wrong side out (asymmetrical tyres). (i). An E or e mark is not visible on the tyre or not in accordance with the requirements ¹ . (j). Any serious damage to the tyre or a cut in tyre that is longer than 25mm or 10% of section width (whichever is the shorter). (k). A tyre cord is visible or damaged. (l). Tyre tread depth is less than 1.6mm in the centre three-quarters of the tread pattern. (m). Tyre rubbing against other components (flexible anti spray devices). (n). Tyre rubbing against other components (safe driving not impaired). (o). Re-grooved tyres not in accordance with requirements ¹ . (p). Tyre is re grooved so that cord protection layer is affected. (q). Tyre(s) obviously underinflated and cannot be inflated. (r). A tyre is incorrectly seated on wheel rim.	MaD MaD MaD MaD MaD DD MaD MaD MaD DD DD MiD MaD MaD DD MiD MaD

5.2.3. TYRES

CHECK ITEMS	REASONS FOR FAILURE	SEVERITY
<p>Check for:</p> <ul style="list-style-type: none"> s. Lumps, bulges or tears. t. Valve stem damage. u. Valve stem damage. v. Unacceptable repairs. w. Tyre Pressure Monitoring System. x. Tread depth 	<ul style="list-style-type: none"> (s). The ply or cord structure is ruptured or exposed, tread is lifting, a lump or bulge has been caused by separation of rubber from cords or weakness in cord structure, or tread distorted or damaged. (t). Obvious damage or distortion of a valve stem is present. (u). A valve stem is chafing against valve hole. (v). Tyre has been repaired with the use of a repair plug outside of the central three-quarters tread area. (w). In a vehicle first registered on or after 1 January 2015, Tyre pressure monitoring system (TPMS) malfunctioning or obviously inoperative. (x). Tyre tread wear indicator becomes exposed. 	<ul style="list-style-type: none"> DD MaD MaD MaD MaD MaD

Figure 1. Repairable/Non-repairable Tyre areas

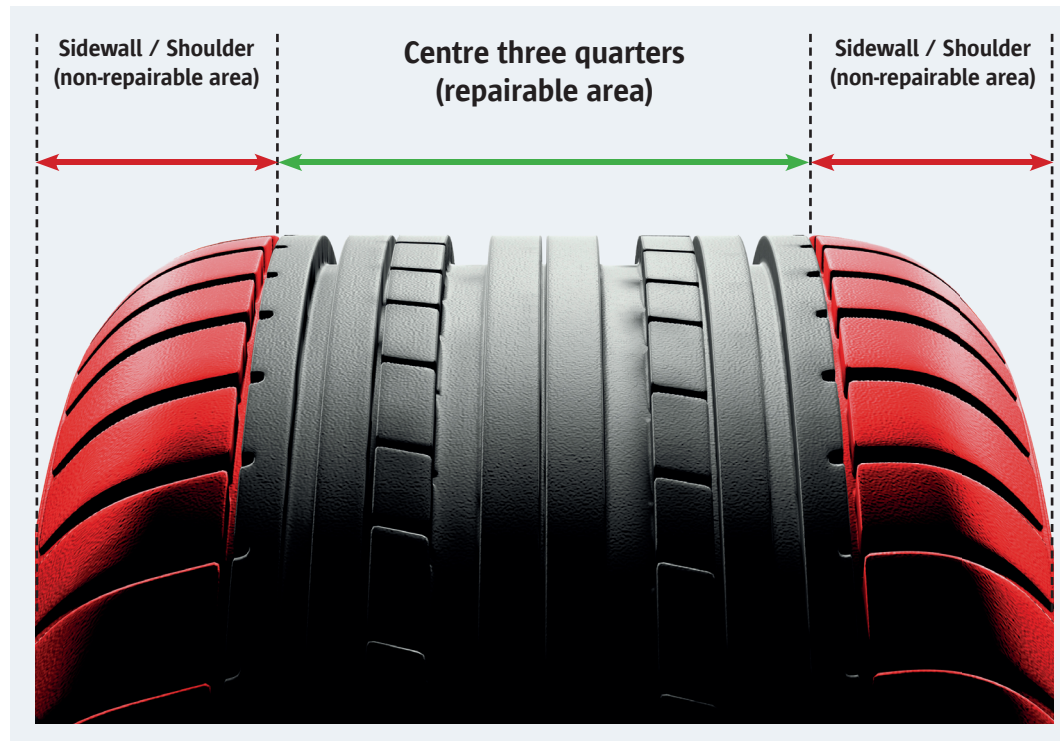
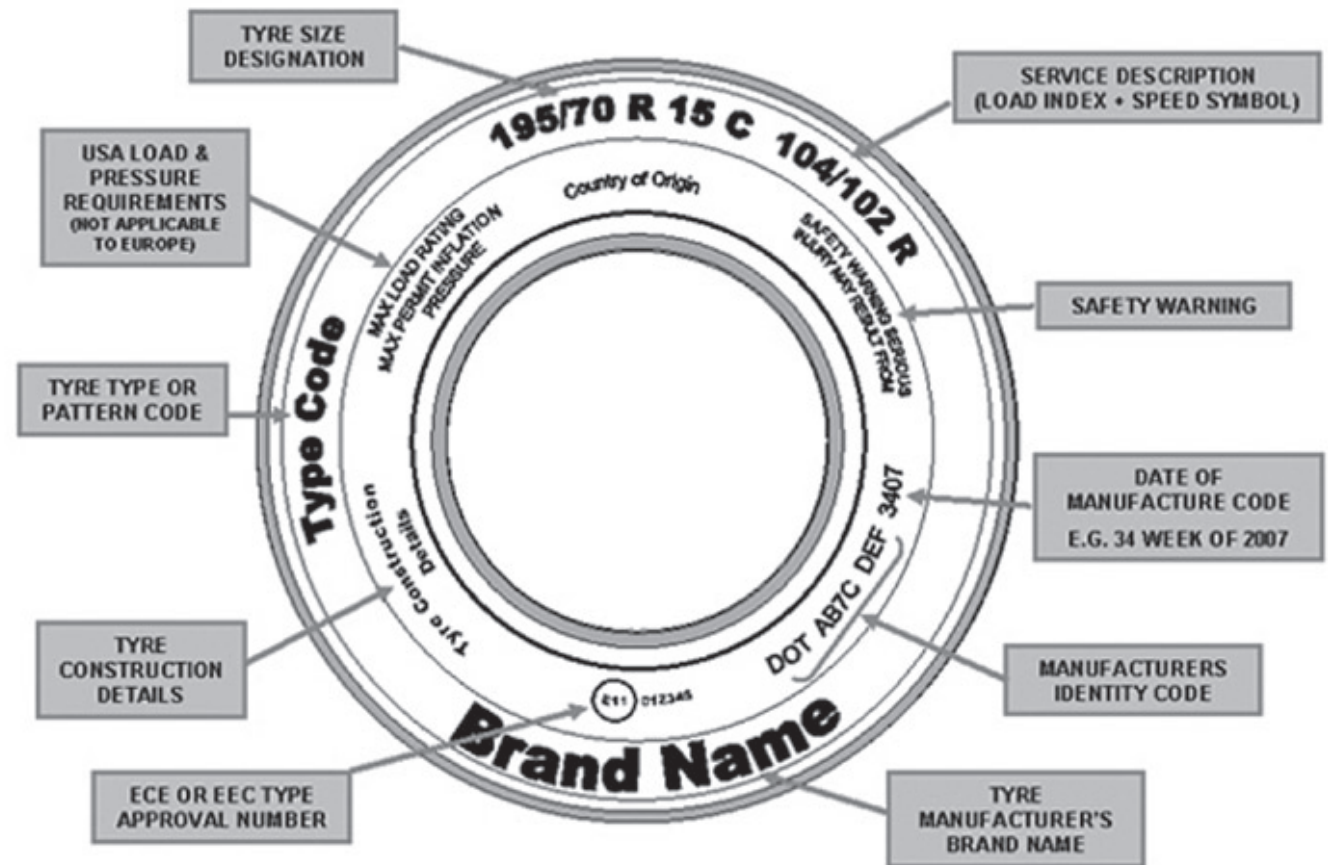

Figure 2. Tyre Speed Rating

CODE	KM/H	CODE	KM/H
A1	5	L	120
A2	10	M	130
A3	15	N	140
A4	20	P	150
A5	25	Q	160
A6	30	R	170
A7	35	S	180
A8	40	T	190
B	50	U	200
C	60	H	210
D	65	V	240
E	70	Z	over 240
F	80	W	270
G	90	(W)	over 270
J	100	Y	300
K	110	(Y)	over 300



The speed rating of a tyre indicated by speed symbol which is made up of a single letter or an A with one number. It indicates the maximum speed at which the tyre can carry a load corresponding to its Load Index.

5.3. Suspension System

5.3.1. SPRING (COIL/LEAF), STABILISER AND TORSION BAR

Method of testing

1. Position the vehicle over the lift with its front wheels aligned over the wheel play detector plates with the brakes applied, operate the plates and observe suspension/ spring attachment points. Check spring (coil/leaf), stabiliser and torsion bar for presence, condition, security, any unsafe repair or modification. Check for the presence and condition of bump stops.

Leaf springs

2. Examine each spring for its general condition and in particular for fractures in the leaves, especially in the vicinity of the anchor eye of the main leaf.
3. Note whether any spring is so weak that is not holding the body sufficiently far away from the wheels.
4. Examine condition of spring eyes/bushes.
5. Examine spring clamps to see that none is missing or insecure, thus allowing leaves to splay.
6. Check that the springs on each axle are symmetrically located.
7. Check that there is no movement of spring leaves denoting a fractured centre bolt.
8. Check that the attachments of the shackle/anchor brackets to the chassis are secure, looking for signs of movement of rivets or bolts, and elongated holes.
9. Examine the bolts and/or nuts securing the spring to the axle for tightness, and examine the spring and axle for evidence that these have been moving relative to each other.

Coil Springs

10. Examine each spring for its general condition and in particular that it is not broken, fractured or cut.
11. Note whether any spring is so weak that it is not holding the body sufficiently far away from the wheels.
12. Examine the attachment of the coil springs for security.

5.3. Suspension System

5.3.1. SPRING (COIL/LEAF), STABILISER AND TORSION BAR

Method of testing

Torsion Bars

13. Check torsion bars for fracture or damage.
14. Examine the attachment of the torsion bars.

Spring Pins and Bushes

15. Examine the amount of play due to wear at spring anchor brackets and pins of the spring shackles.
16. Examine the condition and security of any slipper brackets.
17. Check that the anchor/shackle pins are fully in place, that they are secure and that the locking devices are in position and secure.
18. Examine the spring mountings for excessive side play.

Notes

- A bush and/or pin would be considered excessively worn if wear exceeded 2mm for 13mm diameter pins, 3mm for 25mm diameter pins and 1/8th of diameter for pins over 25mm diameter.
- Caution should be exercised in the case of springs and suspensions with rubber/compliant mountings where the amount of free movement in new components might well exceed the above limit. In such cases the manufacturer's tolerances should be sought. Observation of the vehicle attitude when stationary can often reveal the effect of exhausted or broken springs, e.g. vehicle "sitting down" at front.
- A suspension bump stop should not be confused with rubber/synthetic suspension spring assistors.
- An unsafe repair or modification carried out to the spring (coil/leaf)/torsion bar may require a modifications report to be presented.

5.3. Suspension System

5.3.1. SPRING (COIL/LEAF), STABILISER AND TORSION BAR

CHECK ITEMS	REASONS FOR FAILURE	SEVERITY
<p>Check for:</p> <ul style="list-style-type: none"> a. Security (spring mounting). b. Excessive movement. c. Condition & wear (spring). d. Condition (road safety affected). e. Presence (spring(s)). f. Repairs/Modifications. g. Clearance. h. Correct fitment (spring). i. Condition / repairs. j. Presence & security (U-bolt). k. Condition (coil spring / torsion bar). l. Presence & security (locking device). m. Condition (spring eye-bolts/shackle pins). n. Security (spring eye-bolts/shackle pins). o. Presence & condition (bushings or slipper pads). p. Presence & condition (centre bolt). q. Presence & condition (bump stop). 	<ul style="list-style-type: none"> (a). Spring/torsion bar mounting is obviously loose/broken, cracked or damaged. (b). Relative movement visible fixings very seriously loose. (c). A damaged, cracked, fractured, worn or exhausted spring component (including clamps). (d). Main spring (coil/leaf), or additional leaves very seriously affected. (e). Spring missing. (f). Any obviously unsafe modification² or repair. (g). Insufficient clearance to other vehicle parts; spring system inoperative. (h). Spring (coil/leaf) or torsion bar fitted incorrectly. (i). Any Leaf spring is broken or repaired by welding. (j). A U-bolt is loose or missing. (k). A coil spring or torsion bar is broken/cut. (l). A locking device is missing or insecurely fitted. (m). Spring eye-bolts/shackle pins are worn, incorrectly positioned, are of an incorrect type or are missing. (n). A spring eye-bolt/shackle pin is obviously loose in its bush. (o). Spring or shackle bushes or slipper pads: are worn, missing, perished or cracked. (p). A spring centre bolt missing, damaged or broken. (q). A bump stop is removed damaged or ineffective. 	<ul style="list-style-type: none"> MaD DD MaD DD DD MaD DD MaD MaD MaD MaD MaD MaD MaD MaD MaD MaD

5.3. Suspension System

5.3.2. SHOCK ABSORBER(S)

Method of testing

1. Drive the front and rear wheels of the vehicle onto the suspension performance tester and operate as per manufacturer's instructions.
2. Check each shock absorber and mounting bracket to see that they are correctly connected and in good condition.
3. Check for damage or excessive corrosion of any suspension strut mounting, wear in the shaft and the condition of the bonding between the metal and flexible material in the strut support bearing. This inspection must be conducted with the wheels clear off the ground.
4. Check the condition of any pivots.
5. Check each shock absorber for damage, corrosion and security of attachment.
6. Check each shock absorber for fluid leaks.

Notes

- A slight oil film on the piston rod of a shock absorber is not a reason for failure. Whereas an oil film that runs down the shock absorber indicates a leak and is a reason for failure.
- Damage or corrosion to the outer sleeve of a shock absorber is not a reason for failure unless detachment is imminent. Surface corrosion on a shock absorber casing is not a reason for failure.
- Some MacPherson strut top bushes are designed to have lateral play when the suspension is hanging free. Failure is only justified when play is due to wear and/or maladjustment, etc.

CHECK ITEMS	REASONS FOR FAILURE	SEVERITY
Check:		
a. Presence & condition (shock mounting).	(a). A shock mounting bracket or bush is missing, loose, worn or damaged.	MaD
b. Condition (shock absorber).	(b). Shock absorber loose.	MaD
c. Presence & condition (shock absorber).	(c). A shock absorber is missing or damaged, showing signs of obvious leakage or malfunction.	MaD

5.3.2.1. EFFICIENCY TESTING OF DAMPING

CHECK ITEMS	REASONS FOR FAILURE	SEVERITY
Check:		
a. Imbalance (shock absorbers).	(a). An imbalance of more than 30% performance exists between left and right hand suspension.	MaD
b. Efficiency	(b). Given minimum values not reached.	MaD

5.3.3. TORQUE TUBES, RADIUS ARMS, WISHBONES AND SUSPENSION ARMS & 5.3.4. SUSPENSION JOINTS

(This inspection applies to front and rear suspensions)

Method of testing

1. Position the vehicle over lift with its front wheels aligned over the wheel play detector plates and with the brakes applied, operate the plates and observe suspension/ spring attachment points when checking suspensions, use the vehicle manufacturer's recommended jacking points (front and rear). Certain vehicles will have to be jacked slightly in order to examine the suspension properly. In the absence of manufacturer's recommendations, see 2, 3 and 4 below.
2. Carry out the following checks whichever are relevant to the suspension type fitted by using a suitable bar under each wheel in turn and levering upwards and observe relative vertical movement between components.
3. When jacking vehicles with front suspension types that have the torsion bar or spring force acting on the lower suspension arm, they must be jacked under the lower suspension arm so that the suspension spring force is removed from the ball joints (figure 3 types 1 and 5). Beam axles should be jacked under the beam.
4. All other suspension types must be jacked so the suspension hangs freely.
5. As a general guide;
 - (a). For suspension of the type shown in figure 3 type 1 and type 5, jack up the suspension so that the road wheels are clear of the ground and the suspension is as near as possible to normal running height. While each wheel is held at the top and bottom and rocked, examine for movement in the top and bottom ball joints and movement in the wishbone bushes.
 - (b). For suspensions of the type shown in figure 3 type 2 and type 3, jack up the suspension so that the road wheels are clear of the ground and shake each road wheel vigorously laterally and vertically to determine the condition of the outer suspension ball joints and movement in the control arms.
 - (c). For suspension of the type shown in figure 3 type 4, jack up the suspension so that the road wheels are clear of the ground.
6. Shake each wheel vigorously laterally and vertically, examine each suspension strut for wear at the strut sliding bush and gland as well as for movement at the strut upper support bearing.
7. Check the condition of wishbones and their inner bearings, ball joints, rubber gaiters, swivel joints, retaining devices, track control arms, anti-roll bars, radius rods and their mounting bushes or washers, leading arms and swinging arms for damage or distortion.
8. Check the condition of the chassis frame and body shell structure in the vicinity of suspension mounting points and suspension sub frame mounting points for fractures, excessive corrosion or distortion.
9. Check if there has been an unsafe repair or modification carried out to the suspension. An unsafe repair or modification carried out to the suspension system may require a modifications report to be presented as per the template in this Manual.

Notes

- The main criteria to be used when making a defect assessment for the above methods of testing are; where the component has reached the stage where it is obviously likely to affect adversely the roadworthiness of the vehicle (dangerous) or where the condition of the component has clearly reached the stage at which replacement, repair or adjustment is necessary (major).
- Where the gaiter on the joint of an anti-roll bar link rod is torn, damaged or missing this should not be considered a reason for failure. Anti-roll bar link rods should be assessed for presence, security, condition and obvious wear.
- Anti-roll bar components should be checked for wear while operating the wheel play detector, applying hand pressure or the use of a suitable bar to check for movement. In the absence of manufacturer's tolerance on wear between an anti-roll bar and a bushing, a bushing would be considered obviously worn if wear exceeds 1.5mm for a 25mm diameter bar.

5.3.3. TORQUE TUBES, RADIUS ARMS, WISHBONES AND SUSPENSION ARMS

CHECK ITEMS	REASONS FOR FAILURE	SEVERITY
<p>Check:</p> <p>a. Condition & security (wishbones, swinging arm, track control arm and suspension strut).</p> <p>b. Condition & security (anti-roll bar, torque arm/rod and radius rod/link).</p> <p>c. Condition & security (suspension mounting area).</p> <p>d. Suspension geometry.</p> <p>e. Repairs/modifications.</p> <p>f. Clearance.</p>	<p>(a). I. Wishbones, swinging arm, track control arm, suspension strut: attachment of component to chassis or axle is insecure or obviously worn.</p> <p>II. Wishbones, swinging arm, track control arm, suspension strut: attachment of component so insecure that directional stability of the vehicle is impaired.</p> <p>III. Wishbones, swinging arm, track control arm, suspension strut: a component or mounting is cracked, corroded, damaged or deformed.</p> <p>(b). I. Anti-roll bar, torque arm/rod, radius rod/link: a component is missing or broken.</p> <p>II. Anti-roll bar, torque arm/rod, radius rod/link: a component is loose or obviously worn.</p> <p>III. Anti-roll bar, torque arm/rod, radius rod/link: a component is cracked, damaged or deformed.</p> <p>(c). Suspension mounting area deformed or corroded to such an extent that the security or alignment of the suspension component is affected.</p> <p>(d). Geometry obviously incorrect.</p> <p>(e). Any obviously unsafe repair or modification² to the suspension system.</p> <p>(f). Any obviously unsafe repair or modification² to the suspension system, insufficient clearance to other vehicle parts; system inoperative.</p>	<p>MaD</p> <p>DD</p> <p>MaD</p> <p>MaD</p> <p>MaD</p> <p>DD</p> <p>MaD</p> <p>MaD</p> <p>DD</p>

5.3. Suspension System

5.3.4. SUSPENSION JOINTS

CHECK ITEMS	REASONS FOR FAILURE	SEVERITY
Check: a. Condition & security (swivel pin and/or bushes). b. Excessive wear (stability affected). c. Presence & condition (retaining/locking device). d. Presence & condition (dust covers/gaiters).	(a). Excessive wear in swivel pin and/or bushes or at suspension joints or a component is insecure or worn. (b). A component is so excessively worn or loose that directional stability of the vehicle is impaired. (c). Retaining or locking devices missing, insecure, worn or broken. (d). Dust covers/gaiter split, damaged/ displaced, missing or severely deteriorated.	MaD DD MaD MaD

5.3. Suspension System

Figure 3. Suspension Types

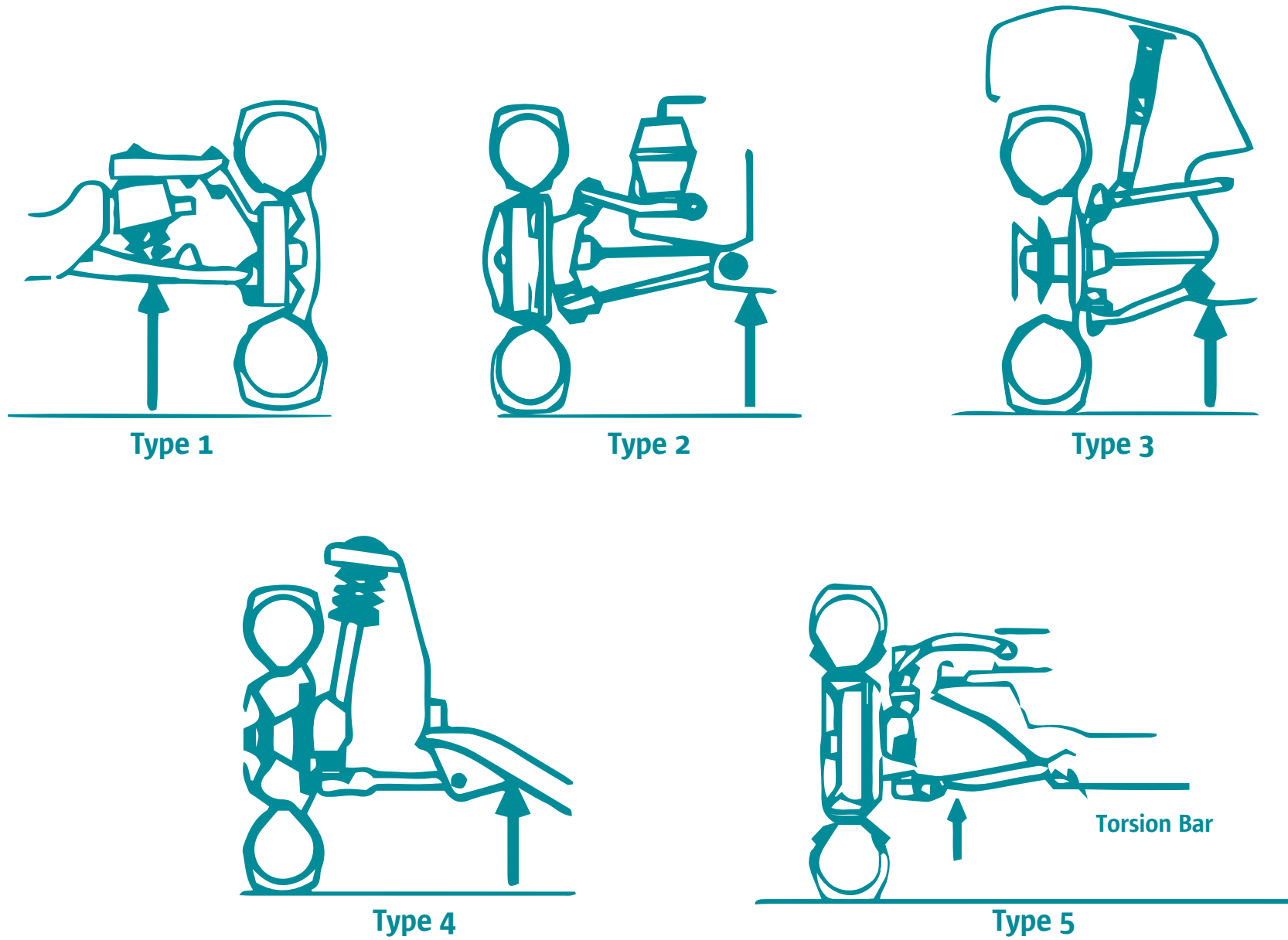

6. CHASSIS, CAB AND BODYWORK

CONTENTS

6.1. CHASSIS OR FRAME AND ATTACHMENTS	109
6.1.1. GENERAL CONDITION	109
6.1.2. EXHAUST PIPES AND SILENCERS	110
6.1.3. FUEL TANK AND PIPES (INCLUDING HEATING FUEL TANK AND PIPES)/SYSTEM	111
6.1.4. BUMPERS, LATERAL PROTECTION AND REAR UNDERRUN DEVICES	113
6.1.5. SPARE WHEEL CARRIER (IF FITTED)	114
6.1.6. MECHANICAL COUPLING AND TOWING DEVICE	115
6.1.7. TRANSMISSION	116
6.1.8. ENGINE/GEARBOX MOUNTINGS	117
6.2. CAB AND BODYWORK	118
6.2.1. GENERAL CONDITION (CAB/VAN/BODY)	118
6.2.2. MOUNTING (CAB & BODY TO CHASSIS)	121
6.2.3. DOORS AND DOOR CATCHES	123
6.2.4. FLOOR	124
6.2.5. DRIVER'S SEAT	124
6.2.6. OTHER SEATS (PASSENGER SEATS)	125
6.2.7. DRIVING CONTROLS	126

6. CHASSIS, CAB AND BODYWORK

6.1. Chassis or Frame and Attachments

6.1.1. GENERAL CONDITION

Method of testing

With the vehicle on a raised lift, carry out the following checks:

1. Check cross members for deformation and/or fractures and/or advanced corrosion. Pay particular attention to a chassis or underbody which is encrusted with dirt. There may be cracks or fractures in high stress areas obscured by this dirt.
2. Check the welding and/or securing bolts/rivets for soundness and security. Pay particular attention to areas around spring and running gear mountings.
3. Check the frame/cross member junctions for indications of movement.
4. Check if there has been any obviously unsafe repair or modification carried out to the chassis or underbody.

Notes

- The test should be abandoned where a vehicle is presented in such a condition that the tester considers it unsafe to continue because it becomes apparent during the test that certain items cannot be satisfactorily inspected (e.g. dirty).
- The extent of this inspection is limited to that part of the chassis or underbody which can readily be seen without dismantling any part of the vehicle.
- The diagram below indicates the main chassis members of typical vehicle constructions.
- Where misalignment is suspected it may be necessary to confirm that the frame/chassis is within the manufacturer's tolerances.
- Some cars (e.g. rally) may be fitted with additional non-standard underbody protection. If this covering inhibits proper inspection more than the manufacturer's area of cover, it is the responsibility of the owner/presenter to make components accessible for inspection, otherwise the vehicle will fail due to the lack of accessibility.
- While the NCTS manual does not specify a continuous weld, a judgement must be made as to whether the repair maintains the manufacturer's original strength.
- See examples of Surface, Advanced, and Extensive rust in the corrosion assessment section.
- An unsafe repair or modification carried out to the chassis or underbody may require a modifications report to be presented as per the template in this Manual.

CHECK ITEMS	REASONS FOR FAILURE	SEVERITY
Check for:		
a. Condition (cross-member).	(a). Slight fracture or deformation of any side or cross-member.	MaD
b. Condition (cross-member, failure imminent).	(b). Serious fracture or deformation of any side or cross-member.	DD
c. Condition and security (chassis member).	(c). Chassis members are cracked, insecure or pronounced misalignment is present.	MaD
d. Welds (chassis member/brackets).	(d). Chassis members or cross member/bracket weld is breaking away.	MaD
e. Condition (attachments and fasteners).	(e). Insecurity of strengthening plates or fastenings including rivets or bolts (up to 50%).	MaD
f. Condition (attachments, failure imminent).	(f). Majority of fastenings loose; broken or missing (50% or more) insufficient strength of parts.	DD
g. Chassis strength.	(g). The chassis/underbody is considerably weakened by holes.	MaD
h. Advanced corrosion.	(h). Advanced corrosion or other equivalent damage is present which affects the rigidity of the assembly.	MaD
i. Extensive corrosion.	(i). Extensive corrosion that the chassis or frame is seriously weakened (insufficient strength of parts).	DD
j. Repairs and modifications.	(j). Repairs or modifications ² are obviously not in line with manufacturer's recommendations.	MaD

6.1. Chassis or Frame and Attachments

6.1.2. EXHAUST PIPES AND SILENCERS

Method of testing

With the vehicle on a raised lift, carry out the following checks:

1. Check the condition of the exhaust pipes and silencers for security, leaks, fire risk and position (so that fumes are unlikely to enter the driver's or passenger's compartment.)
2. Check if there has been any obvious unsafe repair or modification carried out to the exhaust system. An unsafe repair or modification carried out to the exhaust system may require a modifications report to be presented as per the template in this Manual.

Notes

- This inspection applies to all vehicles with an internal combustion engine, including hybrid vehicles.
- The overall security of the exhaust system should be assessed; one or more exhaust mountings missing may not justify rejection.
- Exhaust noise is assessed under Section 8.
- The presence of catalytic converters and diesel particulate filters is assessed under Section 8.

CHECK ITEMS	REASONS FOR FAILURE	SEVERITY
Check for: a. Security. b. Security (Liable to fall off). c. Condition, fitment and presence. d. Leaks. e. Fire risk. f. Fumes. g. Excessive fumes. h. Repair or modification.	(a). Any exhaust component is insecurely mounted. (b). Any exhaust component is so insecurely mounted that it is liable to fall off. (c). Any exhaust component is damaged, incorrectly fitted, missing or not functioning. (d). Leaks present in exhaust system. (e). A risk of fire is present because of leaks or broken components in exhaust assembly. (f). Fumes entering passenger cab or passenger compartment. (g). Excessive fumes entering cab or passenger compartment danger to health of persons on board. (h). Obviously unsafe repair or modification.	MaD DD MaD MaD MaD MaD DD MaD

6.1. Chassis or Frame and Attachments

6.1.3. FUEL TANK AND PIPES (INCLUDING HEATING FUEL TANK AND PIPES)/SYSTEM

Method of testing

1. Examine the fuel tanks to see that they are suitable, free from advanced rust and are firmly held and secure on their mountings. In the case of Liquid Petroleum Gas/Compressed Natural Gas /Liquid Natural Gas (LPG/CNG/LNG), check that the fuel tank is not damaged.
2. Examine fuel tank straps or supports and mounting brackets to see that they are secure and free from fracture and that none is missing.
3. Examine the mounting bracket bolts to chassis/body to see that they are secure.
4. Where the LPG/CNG fuel tank is fitted inside the vehicle, check that the tank safety valve and filler valve are either piped separately to the outside of the vehicle or contained in a gas tight sub-compartment which is vented to the outside of the vehicle.
5. Check that any ducting used for venting sub-compartments or tank valves is not damaged or blocked.
6. Check that no fuel tank is fitted to the roof of the vehicle.
7. Where LPG/CNG/LNG is fitted, check that the manual hand valve on the tank can be closed off. Or where a solenoid is fitted in place of or as an extra protection for the manual valve, check that it can be heard to open and close when the ignition key is switched on and off with the LPG/CNG/LNG switch in the 'on' position.
8. In CNG systems, a second manual valve will normally be found near the filler valve which is usually in the engine compartment. This should also be checked.
9. Check that a fuel tank cap is present and of the correct type. Check that the fuel cap seal is present and is not damaged.
10. Check that there are no leaks at all from the system in the case of petrol. In the case of diesel, check that there are no leaks such that fuel is dripping on to the ground. In the case of LPG/CNG/LNG, check if a pressure leak (hissing noise) can be heard.
11. Examine fuel pipes to see that they are securely clipped to prevent damage by vibration, chafing or cracking.
12. Check that pipelines/hoses are not damaged or deteriorated (e.g. kinked or flattened) and are not in a position to be fouled by moving parts or the road surface.
13. Check that all components of the fuel system are securely mounted.
14. While seated in the driving position, check that the throttle control is:
 - (a) functionally complete,
 - (b) not cracked, fractured or excessively worn or corroded,
 - (c) not obstructed or impeded in its travel.
15. Check that the excess fuel device on diesel-engine vehicles cannot be readily operated from within the cab if it is of a type which, with the engine running, will cause an increase in smoke.
16. Check that the engine stop control is working satisfactorily on diesel engine vehicles. Where LPG/CNG/LNG is fitted, check that the engine fuel supply solenoids (usually in engine compartment for each fuel used) can be heard to open and close when each fuel system is selected on the dash switch.
17. Check that the air filter is present and securely fitted.

Notes

- The extent of this inspection is limited to those parts which can be seen and which are readily accessible without dismantling.
- All fuel tanks on the vehicle are included in the inspection.
- If a vehicle is presented with a Nitrous Oxide (NO₂) injection system fitted, it should be failed under Reason for Failure (d) below.
- If a fuel tank is seen to be holed, or the filler neck is seen to split it should be considered to be leaking even though a leak may not be evident because the defect is above the fuel line.

6.1. Chassis or Frame and Attachments

6.1.3. FUEL TANK AND PIPES (INCLUDING HEATING FUEL TANK AND PIPES)/SYSTEM

CHECK ITEMS	REASONS FOR FAILURE	SEVERITY
<p>Check for:</p> <ul style="list-style-type: none"> a. Condition and security (fuel tanks and brackets). b. Corrosion (fuel tank). c. Leaks. d. Tank compatibility. e. Fuel tank location (LPG/CNG/LNG). f. Venting or ducting pipes (LPG/CNG/LNG). g. Sub-compartment (LPG/CN/LNG). h. Fuel tank location (external). i. Valve operation. j. Security and condition (Fuel lines). k. Condition and presence (Fuel cap). l. Stopcock operation. m. Risk of fire. n. Throttle control. o. Air filter assembly. p. Compliance with requirements 	<ul style="list-style-type: none"> (a). A component is incorrectly or loosely mounted or damaged. (b). Advanced rust is present in fuel tank. (c). Leaks in system are evident. (d). Unsuitable fuel tank has been fitted. (e). LPG/CNG/LNG tank has been fitted inside vehicle without being in a sub compartment or without having valves piped to the outside. (f). LPG/CNG/LNG venting or ducting pipes are damaged or blocked. (g). Tank has been fitted inside the vehicle without being sub compartmented or the sub-compartment is obviously not gas-tight where valves are not piped to the outside. (h). Fuel tank is fitted to roof of vehicle. (i). Manual or solenoid valve is not operating. (j). Possibility exists of fuel lines being crushed, chafed, ruptured or subject to excessive vibration. (k). No fuel cap, or fuel cap seal is damaged or missing. (l). Fuel cut-off (if required) not operating correctly. (m). <ul style="list-style-type: none"> i. Fire risk due to leaking fuel ii. Fire risk due to fuel tank or exhaust not properly shielded iii. Fire risk due to engine compartment condition iv. Fire risk due to insecure tank or pipes (n). <ul style="list-style-type: none"> i. Throttle control is sticking, binding or excessively worn. ii. Throttle control a link pin, retaining device or safety device is missing. iii. Throttle control mounting bracket or panel is cracked or fractured. iv. Throttle control: excess fuel device gives off excessive smoke if operated from within the passenger compartment after the engine has been started. v. Throttle control: engine stop control (on diesel vehicles) is not working or is missing. (o). Air filter assembly is insecure, missing or incomplete. (p). LPG/CNG/LNG or hydrogen system not in accordance with requirements¹; any part of the system defective. 	<ul style="list-style-type: none"> MaD MaD MaD MaD MaD MaD MaD MaD MaD MaD MaD DD DD DD DD MaD MaD MaD MaD MaD MaD DD DD

6.1. Chassis or Frame and Attachments

6.1.4. BUMPERS AND BULL BARS

Method of testing

With the vehicle on a raised lift, carry out the following checks:

1. Check bumpers, bars for security, jagged edges or damage that could cause injury.
2. Check for any signs of corrosion.

CHECK ITEMS	REASONS FOR FAILURE	SEVERITY
Check for: a. Condition and security (bumper/bull bar). b. Condition and security (bumper/bull bar, failure imminent). c. Security (body strip). d. Compliance.	(a). A bumper/bull bar is loose/damaged or likely to cause injury when grazed or contacted. (b). A bumper/bull bar is so insecurely mounted that it is likely to fall off (functionality heavily affected). (c). Body strip is insecure. (d). Device obviously not in compliance with the requirements ¹ .	MaD DD MaD MaD

6.1. Chassis or Frame and Attachments

6.1.5. SPARE WHEEL CARRIER (IF FITTED)

Method of testing

1. Check the spare wheel carrier, if fitted, for security of attachment to vehicle.
2. Check the mounting points and the structure of the carrier are free from defects.
3. If there is a spare wheel in the carrier, check that this is securely held in the carrier.

Notes

- Defects in a spare wheel tyre should not be considered a reason for failure.
- Where a spare wheel (other than a space saver wheel) is supplied by a vehicle manufacturer for a particular make and model, then it should be accepted as suitable provided it is not speed restricted to less than 120 km/h (75 mph).

CHECK ITEMS	REASONS FOR FAILURE	SEVERITY
Check for: a. Carrier condition. b. Condition and security (carrier). c. Security (spare wheel). d. Security (carrier or spare wheel, risk of detachment).	(a). Carrier not in proper condition. (b). Spare wheel carrier is cracked or insecurely mounted. (c). Spare wheel (where present) is insecurely held in its place. (d). Spare wheel or carrier is so insecurely mounted that there is a very serious risk of it becoming detached.	MiD MaD MaD DD

6.1. Chassis or Frame and Attachments

6.1.6. MECHANICAL COUPLING AND TOWING DEVICE

Method of testing

Carry out the following checks on the drawing coupling:

1. Check the vehicle coupling pin/hook/eye/ball. Note the condition of these components and ensure that they are free from distortion and/or fracture.
2. Check the hook/ball or pin/bushes for wear using a gauge where appropriate.
3. Check the body of the coupling for wear, distortion or cracks.
4. Check the cross member to which the coupling is mounted paying particular attention to the inner face of the cross member for security and cracks.
5. Check that the coupling assembly is securely attached to the vehicle.
6. Check that locking or safety devices are in position and working correctly.
7. Check if there has been an unsafe repair or modification carried out to the coupling.

Notes

- This inspection applies only to vehicles which are fitted with equipment for towing trailers.
- Many 'bolt-on' type couplings have accessory devices sandwiched between the tow ball and its mounting flange. These are not to be considered as inappropriate modifications unless their fitment is clearly likely to adversely affect the roadworthiness of the vehicle/trailer combination.
- Reason for failure (c) may only be selected when the wear is verified using a measuring gauge.

CHECK ITEMS	REASONS FOR FAILURE	SEVERITY
Check for:		
a. Condition (coupling brackets).	(a). Cracks are present in the main parts of the coupling.	MaD
b. Wear (coupling).	(b). Ball or pin is worn, deformed or damaged.	MaD
c. Excessive wear (coupling).	(c). Ball or pin is deformed, damaged or worn beyond limit (e.g. 3mm wear on 50mm ball).	DD
d. Fasteners and securing devices.	(d). Fastening bolts or securing devices are loose or missing.	MaD
e. Security (attachment failure, imminent).	(e). Any attachment loose with a very serious risk of becoming detached.	DD
f. Presence (safety device).	(f). Safety device/lock or blocking device is missing or not operating correctly.	MaD
g. Coupling indicator.	(g). Coupling indicator not working (e.g. warning light).	MaD
h. Registration plate (obscured)	(h). Obstructs registration plate or any lamp.	MiD
i. Registration plate (obscured).	(i). Registration plate not readable (when not in use).	MaD
j. Repair or modification.	(j). Any obviously unsafe repair or modification ² .	MaD
k. Coupling strength.	(k). Coupling too weak.	MaD

6.1. Chassis or Frame and Attachments

6.1.7. TRANSMISSION

Method of testing

With the vehicle on a raised lift, carry out the following checks on the transmission and drive train.

1. Check clutch linkage, clutch pedal anti-slip provision and clutch operation.
2. Check drive shafts (both propeller shafts and half shafts), drive shaft flanges, universal joints bolts/nuts, drive shaft bearings where fitted and the security and condition of the bearing housing.
3. Check universal joints and CV joints for wear, condition and security (including CV boots).
4. Check for excessive oil leaks.
5. Check if there has been an unsafe repair or modification carried out to the engine or power train. An unsafe repair or modification carried out to the engine/powertrain may require a modifications report to be presented as per the template in this Manual.

Notes

- Defects found in gearbox, differential can only be those noted when driving the vehicle at low speed in the test area.
- Drive train includes engine, gearbox, drive shafts, and final drive.
- Excessive leak is any oil leak from any assembly which can deposit oil at a rate of a 75mm diameter pool in 5 minutes or a number of leaks which collectively would deposit oil at the same rate.
- When carrying out this inspection it is important that the vehicle is in neutral gear and that, if a transmission brake is fitted, it is released. Wheels should be chocked.
- It is not always possible to determine the presence and effectiveness of certain types of locking devices e.g. locking fluid or “nyloc” nuts if used instead of split pins on a castellated nut. If the CV joint is secure the absence of a locking device should not be a reason for failure, owner should be advised.
- Clutch pedals that are not equipped with a pedal rubber should not be considered a reason for failure if they were not designed to have one.

CHECK ITEMS	REASONS FOR FAILURE	SEVERITY
Check for: a. Propeller shaft securing bolts. b. Propeller shaft securing bolts (detachment likely). c. Clutch pedal anti-slip provision. d. CV / universal joints wear. e. CV/universal joints (detachment likely). f. Driveline component security. g. Bearing/bearing housing mounting. h. Bearing/bearing housing mounting (detachment likely). i. Locking tabs presence. j. CV joint(s) boot(s) condition and security. k. Excessive oil leaks. l. Propeller shaft or half shaft condition. m. Drive shaft carrier bearing. n. Drive shaft carrier bearing (detachment likely). o. Clutch condition.	(a). Loose or missing propeller shaft or half shaft securing bolts or nuts. (b). Propeller shaft or half shaft securing bolts or nuts so loose or missing that detachment is likely. (c). Clutch pedal anti-slip provision is missing, loose, or worn to the extent that it is no longer effective. (d). Excessive wear at universal joints/coupling or transmission chains/belts. (e). CV/Universal joint(s) or coupling so excessively worn that there is a serious risk of loosening or becoming detached. (f). Driveline component is liable to lock up or break away. (g). Bearing/bearing housing/ housing mounting is askew, damaged or worn. (h). Bearing/bearing housing/ housing mounting is askew, damaged or worn that there is a very serious risk of loosening or becoming detached. (i). Lock tab is missing. (j). CV/ universal joint(s) coupling grease boot(s) is missing, torn or insecure. (k). Excessive oil leak in engine, gearbox or axle. (l). Propeller shaft or half shaft is damaged or bent. (m). Drive shaft/ bearing housing obviously worn/fractured or insecure. (n). Drive shaft/ bearing housing so worn fractured or insecure that there is a very serious risk of loosening or becoming detached. (o). Clutch slips or drags, linkage defective or leaking that driving is impaired.	MaD DD MaD MaD DD MaD MaD DD MaD MaD MaD MaD MaD DD MaD

CHECK ITEMS	REASONS FOR FAILURE	SEVERITY
Check for: p. Gear shift linkage. q. Dust cover condition. r. Dust cover presence and condition. s. Unsafe repair or modification.	(p). Gear shift linkage including gear lever worn or loose that driving is impaired. (q). Dust cover deteriorated. (r). Dust cover missing or severely deteriorated. (s). Any obviously unsafe repair or illegal modification ² to a powertrain/drivetrain component.	MaD MiD MaD MaD

6.1.8. ENGINE/GEARBOX MOUNTINGS

Method of testing

1. Check engine/gearbox mountings for condition and security and their installation to the chassis or underframe.
2. Check for cracks or fractures and signs of deterioration.

Notes

- There will only be a failure under this item if a mounting is no longer capable of performing its function of location and support.

CHECK ITEMS	REASONS FOR FAILURE	SEVERITY
Check for: a. Condition and security (mounting). b. Condition and security (mounting, detachment likely).	(a). Mountings loose, worn, damaged or broken. (b). Mounting so deteriorated damaged or Loose that detachment is likely.	MaD DD

6.2. Cab and Bodywork

6.2.1. GENERAL CONDITION (CAB/VAN/BODY)

Method of testing

With the vehicle on a raised lift, carry out the following checks:

1. Check primary structural components (including floor pan) for cracks, security, damage or rust.
2. Check from both front and rear that the body is sitting squarely.
3. Check all secondary structural components for security, rust or jagged edges.
4. Check that bumpers, guards and body panels are secure and not likely to injure pedestrians or other road users.
5. Check that fumes are unlikely to enter the vehicle e.g. torn gear lever boots.
6. Check that the bonnet and boot lid catches are operating properly. In the case of front opening bonnets, ensure that the safety catch is fitted and operating properly.
7. Check for any unsafe repair or modification. Where repairs have been carried out, check that there is an engineer's report stating that the original strength and safety of the vehicle has not been compromised and that any welding or brazing has been carried out using good engineering practice. Any unsafe repair or modification carried out shall require a modifications report to be presented as per the template in this Manual.

Notes

- Typical Primary Structure Components are illustrated in figure 1 below.
- Secondary Structures include any structure or component which, if it collapsed, would not immediately affect a vehicle's controllability. Normally, surface rust or advanced rust in these structures or components would not make the vehicle unsafe. Extensive rust in these components is usually either hazardous to people in or near the vehicle because of its sharp edges or because exhaust fumes may escape into the vehicle. In such cases, this type of rust would make the vehicle unsafe.
- The term "other similar devices" has a wide interpretation. The criterion to be used is that the road wheels must have associated with them equipment or part of the body which catches, so far as is practicable, mud or water thrown up by the rotation of the road wheels.
- Typical Secondary Components are listed in the corrosion assessment section of this Manual.

6.2. Cab and Bodywork

6.2.1 GENERAL CONDITION (CAB/VAN/BODY)

CHECK ITEMS	REASONS FOR FAILURE	SEVERITY
<p>Check for:</p> <ul style="list-style-type: none"> a. Security and condition. b. Security and condition (likely to fall off). c. Condition (primary structural components). d. Condition (primary structural components). e. Condition (secondary structural components). f. Cab squareness / distortion. g. Presence and condition (bonnet / boot catches). h. Exhaust fumes in cab. i. Repairs and modifications. j. Sufficient clearance. 	<ul style="list-style-type: none"> (a). Loose or damaged panel or part likely to cause injury. (b). Loose or damaged panel or part that it is likely to fall off. (c). Primary structural components broken, cracked, insecure, damaged or rusted to an advanced stage. (d). Primary structural components broken, cracked, insecure, damaged or rusted to an advanced stage that failure is imminent or stability impaired. (e). Secondary structural components missing, insecure, rusted or damaged to such an extent as to leave sharp edges. (f). Body not sitting squarely due to distortion. (g). Bonnet or boot catches. <ul style="list-style-type: none"> (i) Defective/corroded (advanced or extensive corrosion within 100 mm of mounting or locking points). (ii) Bonnet catch defective and safety catch missing. (h). Bodywork so deteriorated or damaged that engine or exhaust fumes are entering the cab. Danger to health of persons on board. (i). Obviously unsafe repair or modification². (j). Insufficient clearance to rotating or moving parts and road. 	<ul style="list-style-type: none"> MaD DD MaD DD MaD MaD MaD DD DD MaD DD

6.2. Cab and Bodywork

Figure 1 Primary Structure Components

Typical Primary Structure Components (as illustrated below) include;

- (1) Main Structural Members such as sub frames and chassis rails.
- (2) Suspension mounting areas.
- (3) Steering box mounting point.
- (4) Door sills and pillars.
- (5) Door hinge mounting areas.
- (6) Seat and safety belt anchorage points.
- (7) All floor panels.
- (8) Bulk head.
- (9) Body Structural Members.

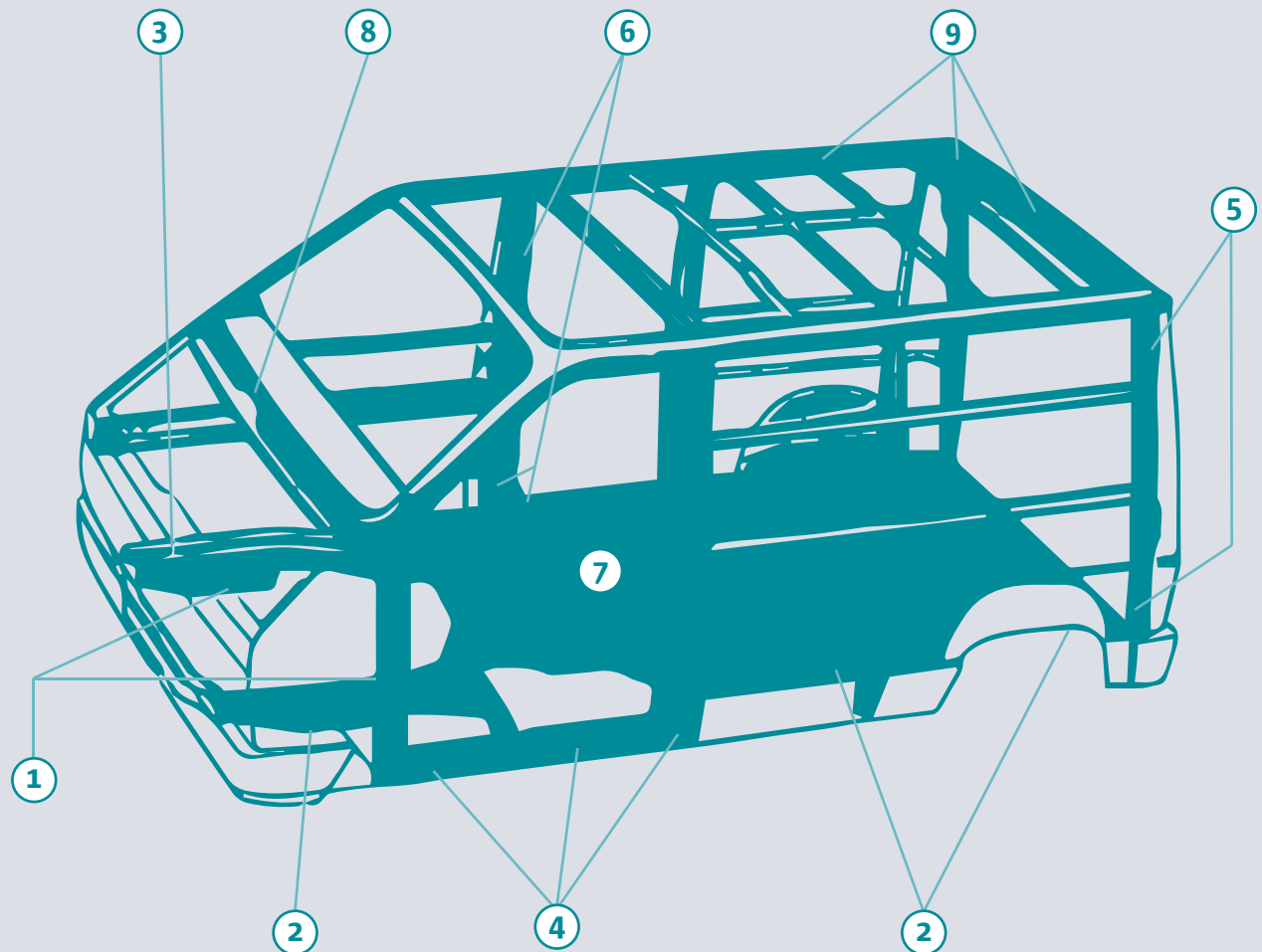

6.2. Cab and Bodywork

6.2.2. MOUNTING (CAB & BODY TO CHASSIS)

Method of testing

With the vehicle on a raised lift, carry out the following checks:

1. Check the mounting of both the cab and body (where applicable) to the chassis. Particular attention should be paid to the general security and any displacement of either the cab or body relative to the chassis. The inspection should cover all fixings securing the body to the chassis or to a sub-frame or supporting members.
2. Check for advanced and excessive corrosion, cracks, or damage to a load bearing member (e.g. cross or longitudinal members) such that the integrity of the body is affected.

Notes

- All means of securing the cab and body to the chassis are to be inspected where practical. Movement which is designed into mountings should not be confused with insecurity or excessive wear.
- Corrosion Assessment – Before carrying out the assessment, testers should familiarise themselves with the corrosion assessment section of this Manual. The inspection should determine whether advanced corrosion exists first by visual inspection and then by finger and thumb pressure. If necessary careful scraping or light tapping of the area is permitted. Corrosion affected heavy gauge metal may be tapped harder than light gauge, but unwarranted force and damage must be avoided.

CHECK ITEMS	REASONS FOR FAILURE	SEVERITY
Check for: a. Security. b. Security (stability affected). c. Body squareness. d. Presence and condition (fixing(s)). e. Presence and condition of (fixing(s), detachment likely). f. Advanced corrosion (body integrity is affected). g. Extensive corrosion (body integrity is affected).	(a). Body insecure. (b). Body so insecure that stability is affected. (c). Body obviously not located squarely on chassis. (d). Insecure or missing fixing of body/cab to chassis or cross-members. (e). Insecure or missing fixing of body/cab to chassis or cross-members to such an extent that detachment is likely. (f). Advanced corrosion on cross or longitudinal members in such condition that the integrity of the body is affected. (g). Extensive corrosion on cross or longitudinal members in such condition that the integrity of the body is seriously affected.	MaD DD MaD MaD DD MaD DD

6.2. Cab and Bodywork

Figure 2. Main Chassis Members.

Main Chassis Members are shown in black.

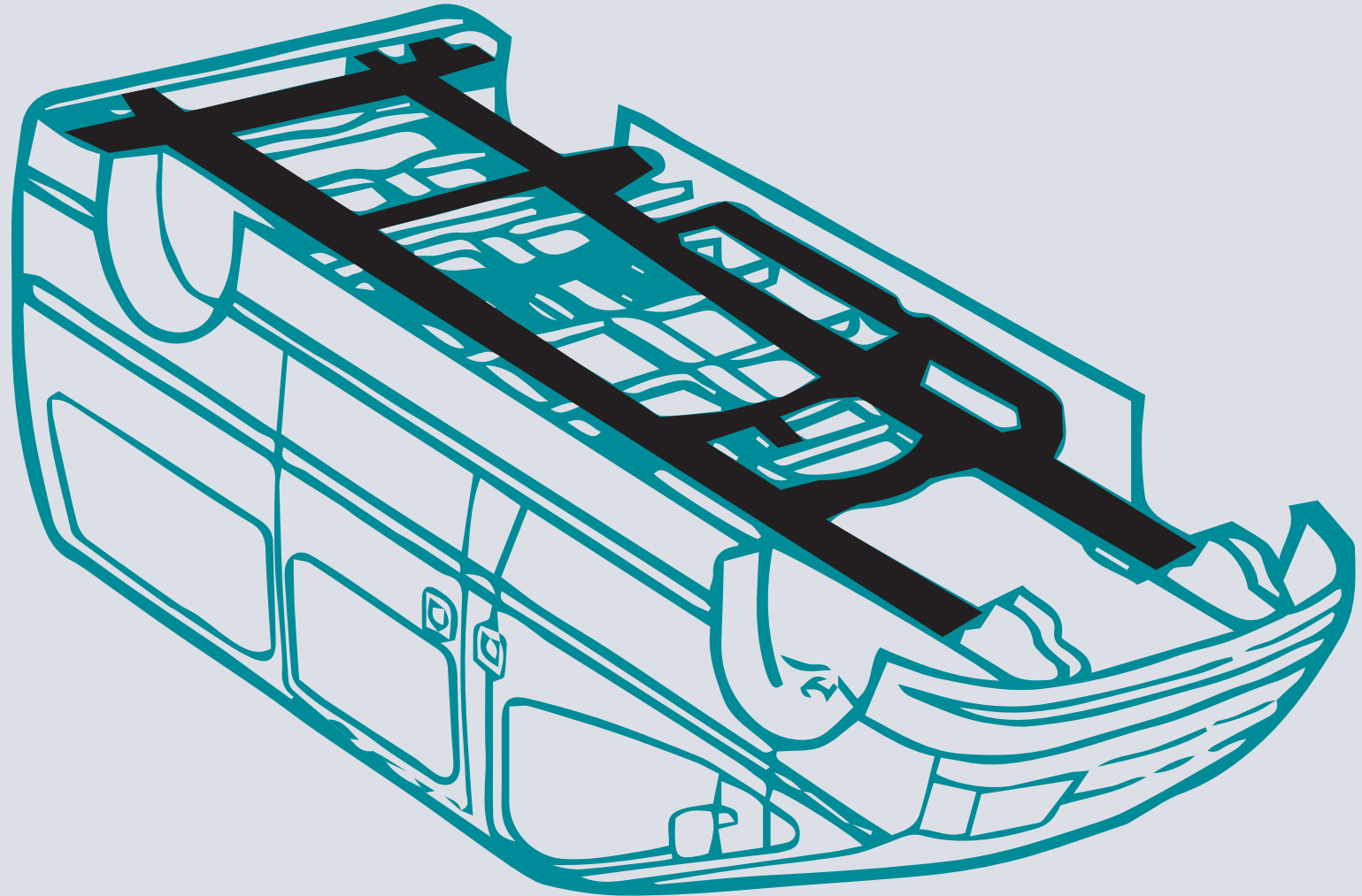

6.2. Cab and Bodywork

6.2.3. DOORS AND DOOR CATCHES

Method of testing

Inspect the condition and operation of the doors and door catches.

1. Check the condition and operation of the doors and door catches fitted to the vehicle. Open and close the driver's and passenger's doors. Check that a door is fitted and can be opened and closed normally. Check that doors are not so worn or damaged such that it is very difficult to open or close them.
2. Check that doors will not open inadvertently and can be opened from both inside and outside the vehicle.
3. By lifting the bottom of the door check for excessive play in the door hinges. Close the door and, without turning the handle, note whether the door primary and secondary catches hold the door closed.
4. By opening and closing each door note whether the door pillars are free from damage and deterioration.
5. If the vehicle is fitted with sliding doors examine the condition of the runners and tracks and actuating mechanism.
6. Check safety devices (where fitted) for non-operation or any defects.

Notes

- The above methods of testing of doors does not apply where a door was not fitted as part of the original design of the vehicle. Similarly, a lack of door handles because of original design characteristics or specialist modification is not considered to be a reason for failure provided the door can be latched securely in the closed position. The driver's and all passenger's doors must be able to be opened from outside. Driver's door must also be able to be opened from inside, using the relevant control in all cases.
- The only requirement for load space doors is that they can be secured in the closed position.
- Door hinges, catches and pillars should only be failed for deterioration if door operation is adversely affected, in the absence of manufacturer's wear tolerance, door hinges should be considered excessively worn if the door cannot be opened and closed normally.

CHECK ITEMS	REASONS FOR FAILURE	SEVERITY
Check for: a. Condition. b. Presence and operation. c. Operation (sliding door). d. Wear, damage or defects. e. Defects (sliding door). f. Safety devices (general).	(a). A door is likely to open inadvertently or one that will not remain closed (turning doors). (b). A door is missing, cannot be opened or shut normally /excessively worn hinges. (c). A sliding door likely to open inadvertently or one that will not remain closed. (d). Door, hinges, catches or pillar deteriorated/missing/ not functioning or loose. (e). Runners, tracks or an actuating mechanism on a sliding door is so defective that the door does not open or close properly. (f). Any safety device is not working or is defective.	DD MaD MaD MaD MaD MaD

6.2. Cab and Bodywork

6.2.4. FLOOR

Method of testing

Visually inspect the vehicle on a raised lift.

1. Check the condition of the floor (including areas around the internal wheel arches).
2. Check for signs of deterioration or insecurity that could affect the driver's stability or impair the driver's control of the vehicle.

Notes

- This inspection applies to the floor in driver, passenger and goods carrying compartments.

CHECK ITEMS	REASONS FOR FAILURE	SEVERITY
Check for:		
a. Condition and security.	(a). Floor insecure or badly deteriorated.	MaD
b. Deterioration (drivers stability affected).	(b). Floor insecure or badly deteriorated that stability is affected.	DD

6.2.5. DRIVER'S SEAT

Method of testing

Visually inspect the condition and operation of the driver's seat.

1. Check the driver's seat and seat mountings for security and condition noting any movement of the seat relative to the vehicle body and check the condition of the seat back and seat cushion.
2. Check for collapsed or damaged framework and damage to seat cushion / support foam such that the driver's support or stability may be impaired.
3. Check that the driver's seat position adjusting mechanism is functioning properly (i.e. can be adjusted forwards and backwards and secured in the selected positions) and that the backrest can be secured in its normal upright position.

Notes

- A seat should fail when it is so loose that detachment from the runners or sliding backwards or forwards is likely. The driver's seat should be failed where the seat support foam cannot be contained, e.g. keeps falling out. This does not mean the seat fails if the upholstery is torn or worn. A seat cover is an acceptable means of containing the foam.
- When inspecting the driver's seat adjustment mechanism it is not necessary to check that the seat can be secured in all possible positions.
- Where a vehicle is fitted with electrically adjusted seats, it is not necessary to check any 'memory position' function(s).

6.2.5. DRIVER'S SEAT

CHECK ITEMS	REASONS FOR FAILURE	SEVERITY
Check for: a. Security. b. Framework damage. c. Condition (seat and cushion). d. Operation (adjustment controls). e. Operation (backrest controls).	(a). Loose on runners or insecurely mounted that the stability is affected. (b). Collapsed or framework damaged. (c). Driver's seat so damaged that driver's support is impaired or interior foam is protruding beyond the seat trim. (d). Driver's seat adjustment mechanism not functioning correctly. (e). Seat moving or backrest not fixable.	DD MaD MaD MaD DD

6.2.6. OTHER SEATS (PASSENGER SEATS)

Method of testing

Visually inspect the condition and operation of seats other than the driver's seat (i.e. passenger seats).

1. Check the seat and seat mountings for security and condition noting any movement of the seat relative to the vehicle body and check the condition of the seat back and seat cushion. Check for collapsed or damaged framework and damage to seat cushion or support foam.

Notes

- A seat should fail when it is so loose that detachment from the runners or sliding backwards or forwards is likely.
- A seat shall not fail for slight tears or wear to the upholstery. A seat cover is an acceptable means of containing the foam.
- Main parts includes components such as; seat frames while secondary parts include; seat cushion, back rest etc.
- Child seats where fitted will be assessed under security of fitting, seat cushion, backrest etc.

CHECK ITEMS	REASONS FOR FAILURE	SEVERITY
Check for: a. Condition and security (secondary parts). b. Condition and security (main parts). c. Seating number. d. Compliance.	(a). Seats in defective condition or insecure (secondary parts). (b). Seats in defective condition or insecure (main parts). (c). Seats not fitted in accordance with requirements ¹ . (d). Permitted number of seats exceeded; positioning not in compliance with approval.	MiD MaD MiD MaD

6.2. Cab and Bodywork

6.2.7. DRIVING CONTROLS

Method of testing

This inspection applies to driving controls that are not covered in other sections of this Manual, for example adaptations for disabled drivers.

1. Visually check that any control necessary for the safe operation of the vehicle is functioning correctly.
2. While sitting in the driver's seat, by operating the driving controls, where appropriate, check that they are:
3. Functioning correctly and not obstructed or impeded in their travel.
4. Positioned so that they can be satisfactorily operated without impairing proper control of the vehicle.
5. Not worn, insecure, sticking, fouling or likely to fail.
6. In the case of a vehicle fitted with adaptations for disabled drivers that a servo or electrical device is not obviously defective.
7. In the case of a vehicle fitted with adaptations for disabled drivers that wiring is secure, insulation is not damaged or is likely to short circuit or fail.

CHECK ITEMS	REASONS FOR FAILURE	SEVERITY
Check for: a. Safe Operation. b. Safe operation (safety affected). c. Condition and operation (adaptations for disabled drivers).	(a). Any control necessary for the safe operation of the vehicle not functioning correctly. (b). Any control necessary for the safe operation of the vehicle not functioning correctly such that safe operation is affected. (c). Adaptations for disabled drivers i. Any adaptation is worn, insecure, sticking, fouling or likely to fail. ii. A servo or electrical device is defective. iii. Wiring is insecure, insulation is damaged or is likely to short circuit or fail.	MaD DD MaD MaD MaD

7. SAFETY RESTRAINTS, LOCKS, HORN, SPEEDOMETER, ESC, ECALL

CONTENTS

7.1. SAFETY-BELTS/BUCKLES AND RESTRAINT SYSTEMS	128
7.1.1. SECURITY OF SAFETY-BELTS/BUCKLES MOUNTING	128
7.1.2. CONDITION OF SAFETY-BELTS/BUCKLES	129
7.1.3. SAFETY BELT LOAD LIMITER (WHERE FITTED)..	130
7.1.4. SAFETY BELT PRE-TENSIONERS	130
7.1.5. AIRBAG(S)	131
7.1.6. SRS SYSTEMS	132
7.3. LOCKS AND ANTI-THEFT DEVICES	132
7.7. HORN (AUDIBLE WARNING DEVICE)	133
7.8. SPEEDOMETER	133
7.11. ODOMETER	134
7.12. ELECTRONIC STABILITY CONTROL (ESC)	134
7.13 ECALL	135
7.13.1 ECALL FITMENT AND CONFIGURATION	135
7.13.2 ECALL CONDITION	135
7.13.3 PERFORMANCE	136

7. OTHER EQUIPMENT

7.1. Safety-Belts/Buckles and Restraint Systems

(This section does not apply to vehicles registered before the 1st June, 1971)

7.1.1. SECURITY OF SAFETY-BELTS/BUCKLES MOUNTING

Method of testing

1. Pull each safety belt webbing against its anchorage and see that it is properly secured to the vehicle structure.
2. Check the condition of the attachment and adjustment fittings on each belt for distortion or fracture.
3. As far as is practicable without dismantling, check the condition of the vehicle structure in the vicinity of the safety belt anchorage points. The condition of floor mounted anchorage points may best be inspected from underneath the vehicle.
4. Check for any unsafe repairs or modifications to seatbelts or anchorage points.

CHECK ITEMS	REASONS FOR FAILURE	SEVERITY
Check for: a. Condition and security (mounting). b. Repairs or modifications. c. Condition (anchorage points).	(a). Any belt mounting/anchorage is loose or unsatisfactory, e.g. incorrect bolts fitted. (b). Any belt mounting is obviously unsafely repaired or modified ² . (c). Any load bearing member of the vehicle structure or paneling within 30 cm of a safety belt anchorage point is cracked, corroded or is in otherwise weakened condition that stability is affected. This applies to the seat mounting if the belt is anchored to the seat.	MaD MaD DD

7.1. Safety-Belts/Buckles and Restraint Systems

7.1.2. CONDITION OF SAFETY-BELTS/BUCKLES

Method of testing

1. Check the condition of all safety belt webbing for cuts or obvious signs of deterioration. In the case of the retractable type safety belt ensure that the belt is fully extended during this examination.
2. With the seat unoccupied fasten the safety belt buckle and check that the adjustment mechanism functions properly. In the case of retractable belts ensure that all the slack is removed and by pulling the belt quickly check that the locking mechanism operates. Attempt to separate the fastened belt at the buckle and check that the belt can be released when required.
3. Check that the seatbelt malfunction indicator does not indicate a fault in the system.
4. For vehicles registered on or after the 1st day of June, 1971, check that a lap and diagonal type safety belt is provided for the driver and front outer passenger seat.
5. For vehicles registered on or after the 1st day of January, 1992, check that all outer forward facing seats are provided with a lap and diagonal type safety belt and all other forward facing seats are provided with a lap and diagonal or lap type safety belt.

Notes

- Safety belts which only operate when the vehicle is in motion should be checked when driving to or from the test lane.

CHECK ITEMS	REASONS FOR FAILURE	SEVERITY
Check for: a. Presence of seatbelts (vehicles registered between 1 June 1971 and 31 December 1991 (inclusive of those dates)). b. Presence of seatbelts (vehicles registered on or after the 1 January 1992). c. Presence of seatbelts (vehicles registered on or after the 1 January 1992). d. Damage or Repair. e. Compliance. f. Condition (buckle). g. Condition (seatbelt retractor).	(a). For vehicles registered between 1 June 1971 and 31 December 1991 (inclusive of those dates), a lap and diagonal type safety belt is not provided for the driver and outer front seat. (b). For vehicles registered on or after 1 January 1992 : a lap and diagonal type belt is not provided for all outer forward facing seats. (c). For vehicles registered on or after the 1 January 1992 , a lap and diagonal or lap type safety belt is not provided for all other forward facing seats. (d). Any cut, sign of overstretching, badly frayed or obviously unsafely repaired or modified safety belt. (e). Safety-belt not in accordance with the requirements ¹ . (f). Safety-belt/buckle, including any for a child seat attached to the vehicle, is not operating properly or is damaged. (g). Safety-belt retractor, including any for a child seat attached to the vehicle, is not operating properly or is damaged.	MaD MaD MaD MaD MaD MaD

7.1. Safety-Belts/Buckles and Restraint Systems

7.1.3. SAFETY BELT LOAD LIMITER (WHERE FITTED).

Method of testing

1. Visually inspect any safety belt load limiter for deployment.
2. Check that the seatbelt malfunction indicator does not indicate a fault in the load limiter.

Notes

- Some seatbelt systems use load limiters to minimise belt-inflicted injury. The basic idea of a load limiter is to release a little more excess belt webbing when a great deal of force is applied to the belt. The simplest load limiter is a fold sewn into the belt webbing. The stitches holding the fold in place are designed to break when a certain amount of force is applied to the belt. When the stitches come apart, the webbing unfolds, allowing the belt to extend a little bit more.

CHECK ITEMS	REASONS FOR FAILURE	SEVERITY
Check for: a. Presence and condition. b. Malfunction indicator (vehicle interface).	(a). Load limiter obviously missing or not suitable with the vehicle. (b). System indicates failure via the electronic vehicle interface.	MaD DD

7.1.4. SAFETY BELT PRE-TENSIONERS

Method of testing

1. Check for any obvious defect of seatbelt pre-tensioners.
2. Check that the seatbelt malfunction indicator does not indicate a fault in a seatbelt pre-tensioner.

CHECK ITEMS	REASONS FOR FAILURE	SEVERITY
Check for: a. Presence and condition. b. Malfunction indicator (vehicle interface).	(a). Pre-tensioner obviously missing or not suitable with the vehicle. (b). System indicates failure via the electronic vehicle interface.	MaD DD

7.1. Safety-Belts/Buckles and Restraint Systems

7.1.5. AIRBAG(S)

Method of testing

1. Visually check for the presence and suitability of airbags and ensure that no airbag is obviously inoperative.
2. Check that the airbag(s) malfunction indicator does not indicate a fault in the system.

Notes

- A passenger airbag that has been switched off is not a reason for failure.

CHECK ITEMS	REASONS FOR FAILURE	SEVERITY
Check for: a. Presence and condition (airbag). b. Malfunction indicator (vehicle interface). c. Operation (airbag). d. Malfunction indicator.	(a). Airbags obviously missing or not suitable with the vehicle. (b). System indicates failure via the electronic vehicle interface. (c). Airbag obviously non-operative. (d). Malfunction indicator light (MIL) not working, not going through the correct sequence or indicates any kind of failure of the system.	MaD DD MaD MaD

7.1. Safety-Belts/Buckles and Restraint Systems

7.1.6. SRS SYSTEMS

Method of testing

1. Check that the SRS malfunction indicator does not indicate a fault in the system.

Notes

- The SRS malfunction indicator lamp (MIL) may display a symbol similar to that shown, or one depicting a person wearing a safety belt. The SRS (MIL) may indicate that there is a fault in the seatbelt load limiter, pre-tensioners or airbags.



CHECK ITEMS	REASONS FOR FAILURE	SEVERITY
Check for: a. Malfunction indicator. b. Malfunction indicator (vehicle interface).	(a). Malfunction indicator light (MIL) not working, not going through the correct sequence or indicates any kind of failure of the system. (b). System indicates failure via the electronic vehicle interface.	MaD DD

7.3. Locks and Anti-Theft Devices

7.3. LOCKS AND ANTI-THEFT DEVICES

Method of testing

1. Check anti-theft devices (steering door locks and ignition key only).
2. Check that the steering lock is not fouling the steering mechanism when the ignition is switched on.

Notes

- Where a vehicle is not fitted with a steering lock, an ignition key or an immobiliser to prevent vehicle movement, then the doors must be capable of being locked.
- It is acceptable for a steering lock to be missing or inoperative provided the vehicle has an engine immobiliser, or a permanently installed immobilisation device which acts on either the steering, brakes or the transmission.
- Some electronic steering locks, generally on vehicles with keyless ignition systems, will only activate when the driver's door is opened/closed.
- If there is doubt as to whether a steering lock was originally fitted, the benefit of the doubt should be given.

CHECK ITEMS	REASONS FOR FAILURE	SEVERITY
Check for: a. Operation (device). b. Wear (steering lock).	(a). Device not functioning to prevent vehicle being driven. (b). Steering lock, where fitted as original equipment by manufacturer, has excessive wear or is subject to jamming of the lock/barrel/key mechanism.	MiD DD

7.7. Horn (Audible Warning Device)

7.7. HORN (AUDIBLE WARNING DEVICE)

Method of testing

1. Check that the horn control is accessible to the driver when seated.
2. Check the security of the horn and control.
3. Operate the horn control and note that the horn sounds correctly (e.g. cannot be confused with official sirens).

CHECK ITEMS	REASONS FOR FAILURE	SEVERITY
Check for: a. Operation (horn). b. Operation. c. Security (control / horn). d. Sound (confusion with official sirens). e. Compliance	(a). Not working correctly. (b). Not working at all or is not fitted. (c). Control insecure or horn insecurely mounted. (d). Emitted sound likely to be confused with official sirens. (e). Not in accordance with the requirements ¹ .	MiD MaD MaD MaD MiD

7.8. Speedometer

7.8. SPEEDOMETER

Method of testing

1. Check that a speedometer is fitted, working and can be easily seen from the driving seat.
2. Check that the speedometer can be illuminated.
3. Record the odometer reading at the time of the test where an odometer is fitted. After completion of the NCT test, the owner / presenter must verify odometer reading (see Introduction).

Notes

- The speedometer functions check is limited to the movement of the vehicle within the test area.

CHECK ITEMS	REASONS FOR FAILURE	SEVERITY
Check for: a. Visibility to driver. b. Presence. c. Correct operation. d. Operation. e. Illumination. f. Compliance	(a). Speedometer cannot be seen from the driver's seat. (b). Speedometer is missing. (c). Speedometer is not working correctly. (d). Speedometer is not working at all. (e). Illumination of speedometer not working or defective. (f). Not in accordance with the requirements ¹ .	MaD MaD MiD MaD MaD MiD

7.11 Odometer

7.11 ODOMETER

Method of testing

1. Visual inspection, and/or using electronic interface.
2. If the vehicle is fitted with an OBD port, connect the OBD scan tool to verify the mileage.
3. Check the Odometer Mileage matches the OBD Mileage reading.

Notes

- If the current odometer reading is lower than the previous recorded reading or if the OBD does not match the odometer reading an Advisory Pass will apply.

Advisory Pass applies where the current odometer reading is lower than the previous recorded reading.

Advisory Pass applies where the OBD mileage reading does not match the odometer reading.

7.12. Electronic Stability Control (ESC)

7.12. ELECTRONIC STABILITY CONTROL (ESC) (WHERE FITTED).

Method of testing

1. Visually inspect the Electronic Stability Control (ESC) systems for presence and condition of wheel speed sensors, wiring, switches and other components.

CHECK ITEMS	REASONS FOR FAILURE	SEVERITY
Check for:		
a. Presence and condition (wheel speed sensors).	(a). Wheel speed sensors missing or damaged.	MaD
b. Condition (wiring).	(b). Wiring damaged.	MaD
c. Presence and condition (other components).	(c). Other components missing or damaged.	MaD
d. Operation and condition (switch).	(d). Switch damaged or not functioning correctly.	MaD
e. Malfunction indicator.	(e). Malfunction indicator light (MIL) not working, not going through the correct sequence or indicates any kind of failure of the system	MaD
f. Malfunction indicator (vehicle interface).	(f). System indicates failure via the electronic vehicle interface.	MaD

7.13 eCall (applies from 20 May 2023 if fitted, in accordance with EU type approval legislation)

7.13.1. ECALL FITMENT AND CONFIGURATION

Method of testing

1. Visual inspection or using an electronic interface where made possible by the technical characteristics of the vehicle and where the necessary data is made available.

Notes

- Reasons for failure (b) and (c) will not apply until further notice.

CHECK ITEMS	REASONS FOR FAILURE	SEVERITY
Check for: a. Presence and condition. b. Software version. c. System coding.	(a). System or any component missing. (b). Software version incorrect. (c). System coding incorrect.	MaD MiD MiD

7.13.2. ECALL CONDITION

Method of testing

1. Visual inspection or using an electronic interface where made possible by the technical characteristics of the vehicle and where the necessary data is made available.

Notes

- Reasons for failure (c - h) will not apply until further notice.

CHECK ITEMS	REASONS FOR FAILURE	SEVERITY
Check for: a. Condition. b. Malfunction indicator. c. Operation. d. Network connection. e. GPS signal. f. Audio component. g. Power source. h. Malfunction indicator (vehicle interface).	(a). System or components damaged. (b). eCall MIL indicates any kind of failure of the system. (c). eCall electronic control unit failure. (d). Mobile network communication device failure. (e). GPS signal failure. (f). Audio components not connected. (g). Power source not connected or insufficient charge. (h). System indicates failure via the electronic vehicle interface.	MiD MiD MiD MiD MiD MiD MiD MiD

7.13.3. PERFORMANCE

Method of testing

1. Visual inspection or using an electronic interface where made possible by the technical characteristics of the vehicle and where the necessary data is made available.

Notes

- Reasons for failure (a) and (b) will not apply until further notice.

CHECK ITEMS	REASONS FOR FAILURE	SEVERITY
Check for: a. Performance. b. Performance of audio components.	(a). Minimum set of data (MSD) incorrect. (b). Audio components not working in order.	MiD MiD

8. NUISANCE

CONTENTS

8.1. NOISE	136
8.1.1. NOISE SUPPRESSION SYSTEM	136
8.2.1 POSITIVE IGNITION ENGINE EMISSIONS (PETROL)	137
8.2.1.1. EXHAUST EMISSIONS CONTROL EQUIPMENT	137
8.2.1.2. GASEOUS EMISSIONS	138
8.2.2. COMPRESSION IGNITION ENGINE EMISSIONS (DIESEL)	141
8.2.2.1. COMPRESSION IGNITION ENGINE EMISSIONS (DIESEL) CONTROL EQUIPMENT	141
8.2.2.2. OPACITY	144
8.3. ELECTROMAGNETIC INTERFERENCE SUPPRESSION	145
8.3.1. ELECTROMAGNETIC INTERFERENCE SUPPRESSION	145
8.4. OTHER ITEMS RELATED TO THE ENVIRONMENT	146
8.4.1. FLUID LEAKS	146

8. NUISANCE

8.1. Noise

8.1.1. NOISE SUPPRESSION SYSTEM

Method of testing

1. Check the condition of the exhaust pipe and silencer for security and leaks.
2. Check the effectiveness of the silencer in reducing, as far as is reasonable, the noise caused by the exhaust from the engine.
3. Check if there has been any obvious unsafe repair or modification carried out to the exhaust system.

Notes

- An unsafe repair or modification carried out to the exhaust system may require a modifications report to be presented as per the template in this Manual.
- If the tester deems that the level of noise caused by the vehicle exhaust is excessive, the specific level of noise is to be measured. The vehicle must be moved to the sound test area. The vehicle will be required to have a level of noise less than 99dB in order to pass the test.

CHECK ITEMS	REASONS FOR FAILURE	SEVERITY
Check for: a. Excessive noise b. Presence, condition and security.	(a). Vehicle exhaust noise has reached or exceeded a specified level of 99dB. (b). Any part of the noise suppression system (including silencer and exhaust pipe) is loose, damaged, incorrectly fitted, missing or obviously modified ² in a way that would adversely affect the noise levels.	MaD MaD

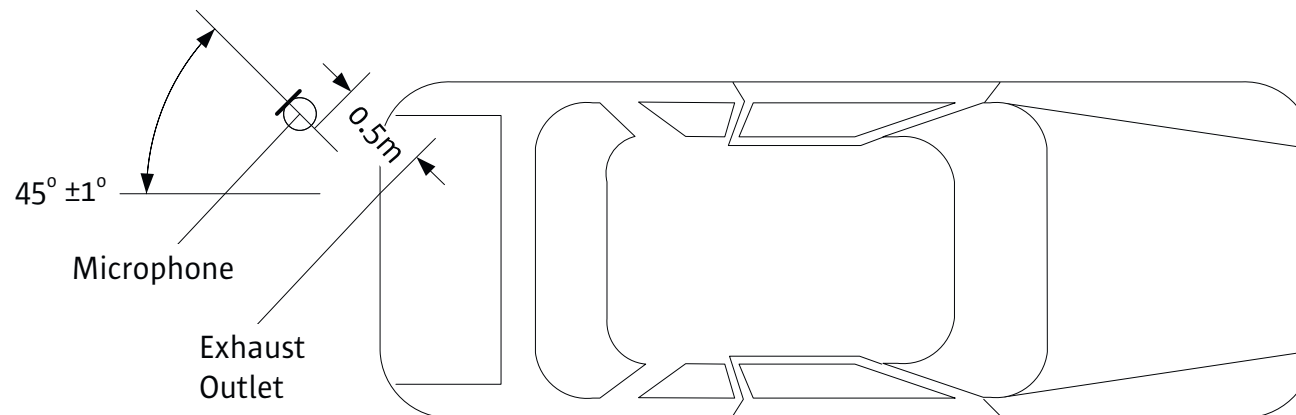

8.2.1 Positive Ignition Engine Emissions (Petrol)

8.2.1.1. EXHAUST EMISSIONS CONTROL EQUIPMENT

Method of testing

1. Check visually that the emission control system is present, complete, properly connected and has not been bypassed.
2. Check if there has been any obvious unsafe repairs or modifications carried out to the exhaust system.
3. Check that the emission control system is not leaking, incomplete or incorrectly assembled, which would affect emission measurements.
4. Check that the engine idle speed is correct (e.g. not more than ± 100 rpm or 10% of manufacturer's stated speed whichever is greater).
5. Check for excessive exhaust smoke likely to affect other road users.

Notes

- A missing exhaust gas recirculation (EGR) valve or catalytic convertor (where either were fitted when the vehicle was originally manufactured), is subject to a failure under reason for failure 8.2.1.1 (a).
- An unsafe repair or modification carried out to the exhaust system may require a modifications report to be presented as per the template in this Manual.
- A durable repair to an exhaust system which effectively prevents leaks is acceptable providing the system is structurally sound.
- A minor exhaust leak (e.g. a connection joint or a pin hole) is not a reason for failure.

CHECK ITEMS	REASONS FOR FAILURE	SEVERITY
Check for: a. Presence, modifications and condition. b. Completeness / unsafe repairs. c. Leaks, incomplete / incorrect assembly. d. Idle speed.	(a). The emission control system fitted by the manufacturer is absent, modified or obviously defective. (b). Exhaust system incomplete, bypassed, incorrectly assembled or obviously unsafely repaired or modified. (c). The emission control system is leaking, incomplete or incorrectly assembled, which would affect emission measurements. (d). Idle speed is outside vehicle manufacturer's recommendations.	MaD MaD MaD MaD

8.2.1. Positive Ignition Engine Emissions (Petrol)

8.2.1.2. GASEOUS EMISSIONS

(This section does not apply to vehicles registered before 1st January, 1980 or fully electric vehicles)

Pre checks:

These pre checks should be carried out before the emissions test is conducted. Where any of the following is noted the tester should not conduct an emissions test and the relevant reasons for failure under section 8.2.1.2 shall be applied.

- The engine warning lamp indicates a defect in the system.
- The oil level is below the manufacturer's minimum level.
- The coolant level is below the manufacturer's minimum level.
- The oil warning light remains on with the engine running.
- The oil level is above the manufacturer's maximum level.
- There are obvious engine defects.

Method of testing

1. Check visually in the case of 4 stroke spark ignition engines (petrol or gas) that the emission control system is complete and properly connected and that there are no leaks in the exhaust system.
2. For vehicles first registered before **January 1994**; with the engine at normal operating temperature connect the CO/HC meter as per manufacturer's instructions or as prompted on screen. Raise the engine speed to approximately 2500 rpm and hold for 20 seconds. Allow the engine to return to idle and the emissions readings to stabilise. Check the carbon monoxide and hydrocarbon content of the exhaust gases at idle speed in accordance with the instructions supplied by the manufacturer of the carbon monoxide and hydrocarbon exhaust gas analyser.
3. For vehicles first registered on or after **1st day of January 1994**; raise the engine speed to 2,500 rpm or to a speed specified by the vehicle manufacturer and hold for a minimum of 30 seconds. Check the HC, CO and Lambda values. If the exhaust emissions are not within the specified limits with the vehicle engine at normal operating temperature raise the engine speed to 2,500 rpm or to a speed specified by the vehicle manufacturer and hold for 3 minutes and note HC, CO and Lambda values. Allow the vehicle engine to return to normal idle speed and the exhaust reading to stabilise and note the CO reading.
4. Measurement using an exhaust gas analyser in accordance with the requirements¹ or reading of OBD in accordance with the manufacturer's recommendations¹ and other requirements

Notes

- Where a vehicle has passed the emissions test and the exhaust system is later found to be leaking, the emissions test must be redone once the exhaust system has been repaired.
- When checking exhaust emissions, the vehicle must be conditioned in accordance with the vehicle manufacturer's recommendations.
- Hybrid vehicles should be viewed as an electric vehicle and will not require an exhaust emissions test.
- For the following Rover vehicles: a) Mini 1300 carburettor and open loop three-way catalyst, b) Metro Rover 100 1100 carburettor and open loop three-way catalyst, **first registered on or before 31 December 1994**, the exhaust emission limit for CO is 3.5% and for HC is 1200 ppm. Where a vehicle meets the CO limit but fails the HC limit, the tester must perform a further HC test at 2000 rpm. If the vehicle meets the HC limit at 2000 rpm, it is considered to have met the requirements.
- For Suzuki Cultas, the maximum allowable CO value is 4.5% and the maximum allowable HC value is 1200 ppm.
- Where it can be established that the vehicle manufacturer's recommendations on exhaust emissions are higher than those listed in the reasons for failure then the manufacturer's figure should be the criteria used when deciding whether or not the vehicle passes.
- For vehicles tested operating on LPG the hydrocarbon reading must be divided by the propane/hexane equivalent factor (PEF) which is marked on the hydrocarbon test equipment.

Notes

- Where vehicles are fitted with twin exhaust systems the higher of the two should be taken.
- A HC test is not required on vehicles operating on CNG.
- For kit cars built before **1st January 2000**, use the pre-1994 emissions standards.
- Where a kit car is presented for a test, with a date of first registration from **1st Jan 2000** onwards a declaration is required from an automotive Engineer/Assessor stating the make, year of manufacture of the engine, and the exhaust emission values stated by the engine manufacturer.
- The 'date of first registration' will be used to provide the test standard. If the test centre manager has information to prove that the car was built to a less stringent standard (such as indicated by the 'year of manufacture'), he may pass the car if it would have passed the less stringent standard.
- If the engine has been changed, apply the standards to which the car was originally built, not the year of manufacture of the engine.
- The HC (hydrocarbon) will only be checked at high idle on cars equipped with catalytic converters.
- Imported and used vehicles **first registered after 1994** that are not fitted with a catalytic converter should be tested against pre-1994 values.
- This test should not be carried out where:
 - (a) the oil warning light remains on with the engine running.
 - (b) the oil level is below the manufacturer's minimum level.
 - (c) the oil level is above the manufacturer's maximum level.
- This test does not apply to two-stroke or rotary piston (Wankel) engines.
- Tailpipe testing shall be the default method of exhaust emission assessment. On the basis of an assessment of equivalence, and by taking into account the relevant type-approval legislation, the use of OBD in accordance with the manufacturer's recommendations and other requirements is acceptable in conjunction with tailpipe testing, for vehicles as of emission classes Euro 5, Euro V, Euro 6 and Euro VI (Type-approved in accordance with Regulation (EC) No 715/2007, Annex I, Table 1 (Euro 5), Table 2 (Euro 6) and Regulation (EC) No 595/2009 (Euro VI).
- Reason for failure (g) will not apply until further notice.

Advisory Pass applies where an error code is detected that is not a reason for failure.

8.2.1. Petrol Engine Emissions

8.2.1.2. GASEOUS EMISSIONS		
CHECK ITEMS	REASONS FOR FAILURE	SEVERITY
Check for:		
a. Oil / coolant levels, oil warning light.	(a). Engine oil level too high or too low, coolant level too low or the oil/engine warning light remains on with the engine running.	MaD
b. Engine defects	(b). Obvious engine defects.	MaD
c. Engine idle speed.	(c). Engine idle speed is incorrect.	MaD
d. Carbon Monoxide levels.	(d). Carbon Monoxide; Either the result of the test on carbon monoxide emissions is not in accordance with the standard for carbon monoxide emissions or as specified by the manufacturer of the vehicle.	
	(i). Carbon monoxide: in the case of vehicles first registered: Before 1 October 1986, the carbon monoxide content is more than 4.5% at idling speed.	MaD
	(ii). Carbon monoxide: in the case of vehicles first registered between 1 October 1986 and 31 December 1993 (inclusive of both dates), the carbon monoxide content is more than 3.5% at idling speed.	MaD
	(iii). Carbon monoxide: in the case of vehicles first registered on or after 1 January 1994, the carbon monoxide content is more than 0.5% at idling speed.	MaD
	(iv). Carbon monoxide: in the case of vehicles first registered on or after 1 January 1994, the carbon monoxide content is more than 0.3% at either an engine speed of 2,500 rpm or at a speed specified by the vehicle manufacturer.	MaD
	(v). Carbon monoxide: in the case of vehicles first registered after 1 July 2002, the carbon monoxide content of the exhaust gases is more than 0.3% by volume at idle speed.	MaD
	(vi). Carbon monoxide: in the case of vehicles first registered after 1 July 2002, the carbon monoxide content of the exhaust gases is more than 0.2% by volume at either an engine speed of 2,500 rpm or at a speed specified by the vehicle manufacturer.	MaD
e. Hydrocarbon levels.	(e). Hydrocarbon	
	(i). Hydrocarbon (HC): the result of the test on hydrocarbon emissions is not in accordance with the standard for hydrocarbon emissions as specified by the manufacturer of the vehicle.	MaD
	(ii). Hydrocarbon (HC): in the case of vehicles first registered before 1 October 1986, the hydrocarbon content is more than 1,000ppm at idling speed.	MaD
	(iii). Hydrocarbon (HC): in the case of vehicles first registered between 1 October 1986 and 31 December 1993 (inclusive of both dates), the hydrocarbon content is more than 750ppm at idling speed	MaD
	(iv). Hydrocarbon (HC): in the case of vehicles first registered on or after 1 January 1994, the hydrocarbon content is more than 200ppm at either 2,500 RPM or at the speed specified by the vehicle manufacturer.	MaD
f. Lambda reading.	(f). Lambda: In the case of vehicles first registered on or after 1 January 1994, the lambda value at either 2,500 rpm or at the speed specified by the manufacturer is not 1+/- 0.03 or is not within the vehicle manufacturer's recommendation.	MaD
g. Malfunction indicators.	(g). OBD indicating significant malfunction.	MaD

8.2.2. Compression Ignition Engine Emissions (Diesel)

8.2.2.1. EXHAUST EMISSIONS CONTROL EQUIPMENT (DIESEL)

Method of testing

1. Check visually that the emission control system is present, complete, properly connected and has not been bypassed and that there are no leaks in the exhaust system.
2. Check if there has been any obvious unsafe repairs or modifications carried out to the exhaust system.
3. With the engine at normal operating temperature, raise the engine speed slowly to half the engine manufacturer's recommended governed speed and hold for 20 seconds in order to purge the exhaust system. If the engine emits any unusual noises the test should be abandoned. Slowly raise the engine speed to its maximum rpm and note if the governor operates within the vehicle manufacturer's recommended rpm setting. If not the test should be discontinued. **Do not hold the engine at maximum rpm for any length of time.**
4. Connect the diesel smoke meter to the vehicle following the smoke meter manufacturer's instructions. Depress the accelerator pedal firmly from the idling position to the maximum fuel delivery position following the prompts of the smoke meter. The smoke meter is programmed to ignore the first reading. The operation is repeated and if the reading on this occasion is less than 60% of the acceptable limit the test is ended. If the reading is not less than 60% of the acceptable limit, the operation is repeated. If the average of this and the previous reading is within the acceptable limit the test is ended. If the average readings are not within the limits the operation is repeated up to a maximum of three more times taking the average of the last two readings after which the test is ended.

Vehicles first registered before 1st January 1980

5. For these vehicles, the exhaust emission should be assessed while driving the vehicle in the test area or test lane. Under no circumstances should the engine rpm be taken above that required to drive the vehicle through the various tests.

Notes

- A missing diesel particulate filter (DPF), exhaust gas recirculation (EGR) valve or catalytic convertor where either were fitted when the vehicle was originally manufactured, is subject to a failure under reason for failure 8.2.2.1 (a).
- An unsafe repair or modification carried out to the exhaust system may require a modifications report to be presented as per the template in this Manual.
- A durable repair to an exhaust system which effectively prevents leaks is acceptable providing the system is structurally sound.
- A minor exhaust leak (e.g. a connection joint or a pin hole) is not a reason for failure.
- All diesel engine tests must be performed according to EU Directives. Where an automatic transmission is fitted, the manufacturer's guidelines should be consulted.
- No smoke test should be carried out without having done the pre-test check.
- It is absolutely essential that the engine is at normal operating temperature before carrying out a smoke test. Testers should ensure that engines are not warmed up by being left idling or at half throttle. They should be warmed up by normal driving.
- Engines left idling for any length of time will show a high smoke opacity reading.
- When carrying out this test the throttle must not be "blipped".
- Exhaust emissions tests should not be performed on a vehicle where the oil level is well over the dipstick "Full" mark.
- Where the oil level is below the minimum level, the exhaust emission test should not be performed if it is necessary to purge the engine.
- Where a diesel engine is at the correct operating temperature and has been correctly purged and the first three readings are at or above 9.99, the exhaust emissions test may be aborted.
- Where a vehicle is producing black smoke to such an extent that the smoke meter might be damaged, the vehicle should be failed without carrying out the normal smoke test (see Test for vehicles first registered prior to 1980.)

Notes

- Vehicles may be tested without preconditioning, although for safety reasons checks should be made that the engine is warm and in a satisfactory mechanical condition.
- Engine shall be fully warm, for instance the engine oil temperature measured by a probe in the oil level dipstick tube to be at least 80 °C, or normal operating temperature if lower, or the engine block temperature measured by the level of infrared radiation to be at least an equivalent temperature. If, owing to the vehicle configuration, this requirement is impractical, the establishment of the engine's normal operating temperature may be made by other means, for example by the operation of the engine cooling fan.
- Exhaust system shall be purged by at least three free acceleration cycles or by an equivalent method.
- Engine and any turbocharger fitted, be at idle before the start of each free acceleration cycle. For heavy-duty diesels, this means waiting for at least 10 seconds after the release of the throttle.
- To initiate each free acceleration cycle, the throttle pedal must be fully depressed quickly and continuously (in less than one second) but not violently, so as to obtain maximum delivery from the injection pump.
- During each free acceleration cycle, the engine shall reach cut off speed or, for vehicles with automatic transmissions, the speed specified by the manufacturer or, if this data is not available, then two thirds of the cut-off speed, before the throttle is released. This could be checked, for instance, by monitoring engine speed or by allowing a sufficient time to elapse between initial throttle depression and release.
- Vehicles shall only be failed if the arithmetic means of at least the last three free acceleration cycles are in excess of the limit value. This may be calculated by ignoring any measurement that departs significantly from the measured mean, or the result of any other statistical calculation that takes account of the scattering of the measurements.
- To avoid unnecessary testing, vehicles may be deemed to have failed which have measured values significantly in excess of the limit values after fewer than three free acceleration cycles or after the purging cycles. Equally to avoid unnecessary testing, may be deemed to pass vehicles which have measured values significantly below the limits after fewer than three free acceleration cycles or after the purging cycles.
- If the fuel pump seal is missing and the maximum rpm achievable is less than 90% of the manufacturer's stated maximum rpm, it should be considered that the fuel pump has been adjusted to pass the test and the vehicle should be failed on this test.
- Where a vehicle has passed the emissions test and the exhaust system is later found to be leaking, the exhaust readings should be overridden.
- The 'date of first registration' will be used to provide the test standard. If the NCTS has information to prove that the car was built to a less stringent standard (such as indicated by the 'year of manufacture'), the may be passed if it would have passed the less stringent standard.
- If the engine has been changed, apply the standards to which the car was originally built, not the year of manufacture of the engine.

*Type-approved in accordance with the Regulation (EC) No 715/2007, Table 2, Annex I (Euro 6). Type approved in accordance with Regulation (EC) No 595/2009 (Euro VI).

** Individual vehicles already built and dispatched from, the manufacturer before 1st June 2015 could be sold until 1st September 2016 (if the manufacturer received a derogation). It is recommended you contact the vehicle manufacturer to check if you are unsure.

CHECK ITEMS	REASONS FOR FAILURE	SEVERITY
Check for: a. Presence, modifications and condition. b. Leaks (emission measurements affected). c. Excessive exhaust smoke (likely to affect other road users).	(a). The emission control system fitted by the manufacturer is absent, incomplete, incorrectly assembled or obviously defective. (b). Leaks which would affect emission measurements. (c). Excess exhaust smoke likely to affect other road users.	MaD MaD MaD

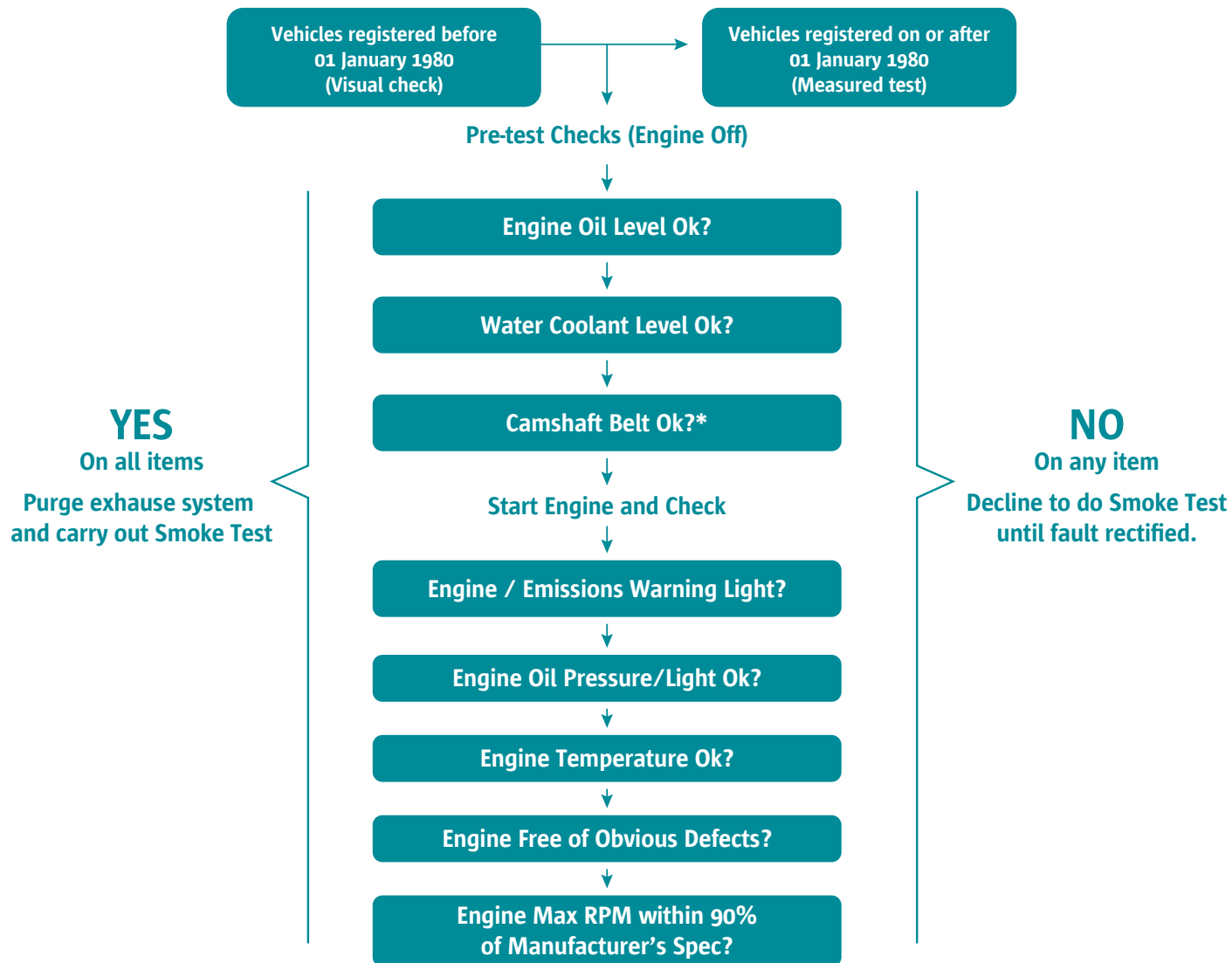

NOTE

Check with the vehicle owner/presenter that the camshaft belt has been changed at the manufacturer's specified interval. Removing the camshaft belt cover is not part of the roadworthiness test.

8.2.2.2. OPACITY

(Vehicles that are purely electric vehicles are exempted from this requirement & vehicles registered or put into service before 1 January 1980 are subject to a visual smoke check)

Pre checks

These pre checks should be carried out before the smoke test is conducted. Where any of the following is noted the tester should not conduct a smoke test and the relevant reasons for failure under section 8.2.2.2 shall be applied.

- The engine warning lamp indicates a defect in the system.
- The oil level is below the manufacturer's minimum level.
- The coolant level is below the manufacturer's minimum level.
- The oil warning light remains on with the engine running.
- The oil level is above the manufacturer's maximum level.
- There are obvious engine defects.

Method of testing

1. With the engine at normal operating temperature, raise the engine speed slowly to half the engine manufacturer's recommended governed speed whichever is less and hold for 20 seconds in order to purge the exhaust system. If the engine emits any unusual noises the test should be abandoned. Slowly raise the engine speed to its maximum rpm and note if the governor operates within the vehicle manufacturer's recommended rpm setting. If not the test should be discontinued. Do not hold the engine at maximum rpm for any length of time.
2. Connect the diesel smoke meter to the vehicle following the manufacturer's instructions. Depress the accelerator pedal firmly from the idling position to the maximum fuel delivery position following the prompts of the smoke meter. The smoke meter is programmed to repeat this operation a minimum of 2 and a maximum of 5 times.

Notes

- Where a vehicle's engine speed is limited when the vehicle is stationary, the smoke test may be carried out at the restricted rpm.
- All diesel engine tests must be performed according to EU Directives. Where an automatic transmission is fitted, the manufacturer's guidelines should be consulted.
- DPF regeneration can sometimes cause diesel to be dumped into the oil, resulting in the maximum oil level (for servicing) being exceeded. The level of oil dilution which different manufacturer's allow varies. Most vehicles use sensors and where there is excessive fuel in the oil a warning light will illuminate. Others have an "X" marked on the dipstick which is above the "max" level. It should not be a reason for failure for vehicles fitted with DPF where the oil level indicated on the dipstick is above the "max" unless the "X" mark is exceeded or the dashboard display indicates excessive fuel in oil.
- If the fuel pump seal is missing and the maximum rpm achievable is less than 90% of the manufacturer's stated maximum rpm with the vehicle stationary, it may be the case that the fuel pump has been adjusted to pass the test and the vehicle should be failed on this test.
- It is absolutely essential that the engine is at normal operating temperature before carrying out a smoke test. Engines should not be warmed up by being left idling or at half throttle. They should be warmed up by normal driving.
- When carrying out the test the throttle must not be "blipped".
- Where a vehicle is producing black smoke to such an extent that the smoke meter might be damaged, the vehicle should be failed without carrying out the normal smoke test (see Test for vehicle registered prior to 1980).
- Reason for failure (h) will not apply until further notice.

Advisory Pass applies where an error code is detected that is not a reason for failure.

8.2.2.2. OPACITY

CHECK ITEMS	REASONS FOR FAILURE	SEVERITY
Check for:		
a. Oil and coolant levels, oil warning light.	(a). Engine oil level too high or too low, coolant level too low, or oil/engine warning light remains on with the engine running.	MaD
b. Engine defects.	(b). Obvious engine defects.	MaD
c. Engine idle speed.	(c). Engine idle speed is incorrect.	MaD
d. Smoke meter readings (pre 1 July 2008).	(d). For vehicles first registered between 1 January 1980 and 1 July 2008 (inclusive of both dates), the average smoke meter reading is higher than 2.5m^{-1} in the case of naturally aspirated compression ignition engines, or the average smoke meter reading is higher than 3.0m^{-1} in the case of turbo charged compression ignition engines.	MaD
e. Emissions not in accordance with manufacturer's specifications.	(e). The result of the test on exhaust smoke emission is not in accordance with the standard for exhaust smoke emission as specified by the manufacturer of the vehicle (recorded on the manufacturer's plate on the vehicle).	MaD
f. Smoke meter readings (post 1 July 2008).	(f). Smoke meter readings are;	MaD
(post 1 September Euro 6 engine).	(i). For vehicles first registered after 1st July 2008: the average smoke meter reading is higher than 1.5m^{-1} .	MaD
	(ii). For vehicles first registered after 1st September 2015 ^{**} : the average smoke meter reading is higher than 0.7m^{-1} for vehicles fitted with Euro 6 engine.	MaD
g. Maximum engine speed.	(g). The maximum attainable engine speed is less than 90% of the maximum speed specified by the manufacturer of the vehicle.	MaD
h. Malfunction Indicators	(h). OBD indicating significant malfunction.	MaD

8.3. Electromagnetic Interference Suppression

8.3.1. ELECTROMAGNETIC INTERFERENCE SUPPRESSION

CHECK ITEMS	REASONS FOR FAILURE	SEVERITY
Check for:		
a. Radio interference.	(a). Not meeting the requirements.	MiD

8.4. Other items related to the environment

8.4.1. FLUID LEAKS

Method of testing

1. Check for any excessive fluid leak, other than water or other fluids referred to in this Manual, likely to harm the environment or to pose a safety risk to other road users.

CHECK ITEMS	REASONS FOR FAILURE	SEVERITY
Check for: a. Excessive fluid leaks. b. Excessive fluid leaks (serious risk to road users).	(a). Any excessive fluid leak, other than water, likely to harm the environment or to pose a safety risk to other road users. (b). Steady formation of drops that constitutes a very serious risk.	MaD DD

GUIDELINES FOR COMPLETING MODIFICATIONS REPORTS

Individuals must first read and fully understand the following important information before completing a modifications report (as per the attached template) in respect of a vehicle presented for NCT testing.

1. Road Traffic (Construction, Equipment and Use of Vehicles) Regulations, S.I. 190 No. of 1963 (as amended)

In accordance with the Road Traffic (Construction, Equipment and Use of Vehicles) Regulations, S.I. 190 No. of 1963 (as amended), all vehicles on public roads must conform to the general principles set down in these Regulations in relation to the condition and maintenance of vehicles. All parts and equipment of every vehicle shall be in good and efficient working order. It is each vehicle owner's responsibility to ensure his or her vehicle is in compliance with the law and maintained in a roadworthy condition at all times.

2. Suitably qualified individual (SQI)

A "suitably qualified individual" (SQI) must have:

- A Mechanical Engineering/Technical Qualification (Level 7 or higher accredited courses) or appropriate accreditation with Engineers Ireland or the Institute of Automobile Engineer Assessors.
- A minimum of 5 years experience of working in a suitable technical environment (preferably automotive or Engineering Environment).
- Access to adequate facilities to carry out a thorough vehicle examination and appropriate professional indemnity insurance.

3. In addition to this report, a vehicle converted from M2 or N1 to M1 requires a letter on official headed paper from the manufacturer or authorised distributor confirming that the vehicle maybe classed as M1 in the converted condition

RSA MODIFICATIONS REPORT TEMPLATE

(Use block caps throughout)

This template should be completed where repairs or modifications are identified which may adversely affect the vehicle roadworthiness (read guidelines and notes before completion)..

VIN:

Registration Number:

Make: _____ **Model:** _____

Variant: _____ **Mileage:** _____ Km Miles (tick one)

This report relates to a modification/ repair (delete where appropriate)

In the case of a modification, give description of: body-type before modification:

and body-type after modification (if changed):

The purpose of the modification / repair is to: (give brief details of why these repairs or modifications were carried out to the vehicle)

List of the repairs or modifications made to the vehicle (including, but not limited to those involving changes to the braking systems, suspension, steering systems, bodywork, safety belts / restraint system, towing / coupling equipment, or chassis alterations):

In relation to the modifications/ repairs listed above, provide a detailed description of each. (Please use another page where necessary).

Notes:

- Give full details of any change to the braking system. Include a schematic diagram with key to the components and confirm on which axle's park brakes are fitted.
- Where available, list any type approval numbers related to the modified systems
- Where available from the component/ system manufacturer, supplementary evidence of compatibility with the type and variant of vehicle concerned may be provided
- Details of the standard of workmanship and specifications (including any certification provided by manufacturer / convertor).

The following table must be completed for any vehicle modifications

	Original		Modified	
EU Category				
EU Bodywork Code				
No. of seats (excluding driver)				
No. of doors				
Fuel / Power Source				
Engine Capacity (cm ³)				
Engine Max. Net Power (kw)				
Engine Number				
Type-Approval Number				
DGVW (Design Gross Vehicle Weight((kg)				
	Design weight	Suspension type	Design weight	Suspension type
Design Axle Weights (kg) and Axle 1				
suspension type (air/coil/leaf/torsion bar) Axle 2				

I declare the information provided in relation to the vehicle referred to in this report:

- a. Is true and correct.
- b. That the modifications/ repairs detailed above have been carried out to the vehicle such that the technical status and integrity of the vehicle and its other components and safety features have not been compromised and that the vehicle is safe to be used on the road and does not present a danger to the vehicle occupants or other road users.
- c. That the vehicle meets with the Road Traffic (Construction, Equipment and Use of Vehicles) Regulations (as amended), the Road Traffic (Lighting of Vehicles) Regulations (as amended) and the Road Traffic (Construction and Use of Vehicles) Regulations (as amended).
- d. That the vehicle meets with the essential technical provisions of the EU Directives to which the modification relates for the year and category of vehicle concerned.

Guidelines for completing Modification / Repair Report Template.

Individuals must first read and fully understand the following important information before completing a modifications report (as per the attached template) in respect of a vehicle presented for NCT testing.

1. Road Traffic (Construction, Equipment and Use of Vehicles) Regulations, S.I. 190 No. of 1963 (as amended)

In accordance with the Road Traffic (Construction, Equipment and Use of Vehicles) Regulations, S.I. 190 No. of 1963 (as amended), all vehicles on public roads must conform to the general principles set down in these Regulations in relation to the condition and maintenance of vehicles. All parts and equipment of every vehicle shall be in good and efficient working order. It is each vehicle owner's responsibility to ensure his or her vehicle is in compliance with the law and maintained in a roadworthy condition at all times.

2. Suitably qualified individual (SQI)

A "suitably qualified individual" (SQI) must have:

- A Mechanical Engineering/Technical Qualification (Level 7 or higher accredited courses) or appropriate accreditation with Engineers Ireland or the Institute of Automobile Engineer Assessors.
- A minimum of 5 years experience of working in a suitable technical environment (preferably automotive or Engineering Environment).
- Access to adequate facilities to carry out a thorough vehicle examination and appropriate professional indemnity insurance.

3. In addition to this report, a vehicle converted from M2 or N1 to M1 requires a letter on official headed paper from the manufacturer or authorised distributor confirming that the vehicle maybe classed as M1 in the converted condition.

FOOTNOTES:

1. 'Requirements⁽¹⁾' are laid down by type-approval at the date of approval, first registration or first entry into service as well as by retrofitting obligations or by national legislation in the country of registration. These reasons for failure apply only when compliance with requirements⁽¹⁾ has been checked.
2. Unsafe modification means a modification that adversely affects the road safety of the vehicle or has a disproportionately adverse effect on the environment or the modification or repair is not presented with a suitable modification report.
3. In a vehicle registered on or after 1 January 1986, windscreen is not marked with approved Standard Mark or equivalent: Australia — AS/NZS 2080 AS/NZS 2080T; Canada — CMVSS 205 (C2); India — IS2553 (PART 2) 1992 (Note 11); China — CCC; Japan — 11-4-21 (Window glass) JISR 3211; South Africa — SABS 1191 / SABS 1193; UK — BS AU I78 / BS 85 7-2 / BS5282; USA — FMVSS 205 (U); ANSI/SAE Z26.1- 1996 (Section 7); Germany — A three-period sine wave followed by the letter D.; Glazing marked Birkholz, Seitz, Roxite, Para Press or Bonoplex.; Glazing marked PMMA (polymethylmethacrylate) or PC (polycarbonate); Europe e-mark to Directive 92/22/EEC; E mark to UNECE Regulation No. 43 with one of the following annotations II, II/P, III, IV.

APPENDIX 1

Combinations of ‘Major Defects’ (MaD) in the same inspection area of the vehicle which shall result in the outcome of the NCT being reclassified as ‘Fail Dangerous’ (DD).

BRAKING EQUIPMENT		
PEDAL/HAND LEVER	PEDAL/HAND LEVER	PERFORMANCE (IMBALANCE)
1.1.2 (b). Service brake anti-slip provision is missing, loose, worn to the extent that it is no longer effective.	1.1.2 (d). Mounting is insecure, badly corroded or worn to the extent that the pedal can be moved from side to side.	1.2.1 (j). The brake cannot be operated progressively.
PEDAL/HAND LEVER	PEDAL/HAND LEVER	PEDAL/HAND LEVER
1.1.2 (a). Pedal travel is excessive, obstructed or insufficient reserve travel.	1.1.2 (c). Brake control not releasing correctly.	1.1.2 (g). Travel in the brake pedal indicates air in the brake system or brakes are in need of adjustment.
BRAKE SERVO UNITS, VALVES, MASTER CYLINDER,	BRAKE LININGS AND PADS	BRAKE DRUMS, BRAKE DISCS
1.1.10 (h). Brake fluid significantly below MIN mark.	1.1.13 (c). Lining or pad contaminated (oil, grease etc.).	1.1.16 (c). Actuator leaking.
BRAKE SERVO UNITS, VALVES, MASTER CYLINDER,	LOAD SENSING VALVE	TEST CONNECTIONS
1.1.10 (h). Brake fluid significantly below MIN mark.	1.1.17 (e). A valve insecurely mounted, leaking or defective.	1.1.22 (b). Damaged, unusable or leaking.
LOAD SENSING VALVE	ANTI-LOCK BRAKING SYSTEM	ANTI-LOCK BRAKING SYSTEM
1.1.17 (b). Valve seized or inoperative (ABS/EBS functioning).	1.6 (a). Malfunction indicator light, not working, not going through the correct sequence or indicates any kind of failure of the system.	1.6 (e). Removed or disabled.
LOAD SENSING VALVE	ELECTRONIC BRAKE SYSTEM	ELECTRONIC BRAKE SYSTEM
1.1.17 (b). Valve seized or inoperative (ABS/EBS functioning).	1.7 (a). Malfunction indicator light, not working, not going through the correct sequence or indicates any kind of failure of the system.	1.7 (e). Removed or disabled.
LOAD SENSING VALVE	ANTI-LOCK BRAKING SYSTEM	ANTI-LOCK BRAKING SYSTEM
1.1.17 (f). The load sensing or brake proportioning valves are damaged, inoperative, obviously incorrectly adjusted or a linkage is sticking	1.6 (a). Malfunction indicator light, not working, not going through the correct sequence or indicates any kind of failure of the system.	1.6 (e). Removed or disabled.
LOAD SENSING VALVE	ELECTRONIC BRAKE SYSTEM	ELECTRONIC BRAKE SYSTEM
1.1.17 (f). The load sensing or brake proportioning valves are damaged, inoperative, obviously incorrectly adjusted or a linkage is sticking	1.7 (a). Malfunction indicator light, not working, not going through the correct sequence or indicates any kind of failure of the system.	1.7 (e). Removed or disabled.

FLEXIBLE BRAKE HOSES	FLEXIBLE BRAKE HOSES	FLEXIBLE BRAKE HOSES
1.1.12 (b). Hoses perished, porous, kinked, twisted, too short or excessively damaged or chafed.	1.1.12 (g). A hose is fouling moving parts.	1.1.12 (d). A hose is bulging under pressure.
RIGID BRAKE PIPES	RIGID BRAKE PIPES	RIGID BRAKE PIPES
1.1.11 (c). Are perished, kinked, damaged or rusted to the extent that the pipe is pitted.	1.1.11 (e). A pipe is fouling moving parts.	1.1.11 (d). Are unsatisfactorily mounted (or misplaced) with the possibility of failing.
BRAKE SERVO UNITS, VALVES, MASTER CYLINDER,	BRAKE LININGS AND PADS	BRAKE DRUMS, BRAKE DISCS
1.1.10 (h). Brake fluid significantly below min.	1.1.13 (a). lining or pad excessively worn/warning light illuminated (min mark reached)	1.1.14 (h). insufficient contact between brake pad and disc.
PEDAL/ HAND LEVER	PEDAL/ HAND LEVER	PEDAL/ HAND LEVER
1.1.2 (b). Service brake anti-slip provision is missing, loose, worn to the extent that it is no longer effective.	1.1.2 (d). Mounting is insecure, badly corroded or worn to the extent that the pedal can be moved from side to side.	1.1.2 (a). Pedal travel is excessive, obstructed or insufficient reserve travel.
PEDAL/ HAND LEVER	PEDAL/ HAND LEVER	PERFORMANCE (IMBALANCE)
1.1.2 (a). Pedal travel is excessive, obstructed or insufficient reserve travel.	1.1.2 (c). Brake control not releasing correctly.	1.2.1 (j). The brake cannot be operated progressively.
LOAD SENSING VALVE	ANTI-LOCK BRAKING SYSTEM	ANTI-LOCK BRAKING SYSTEM
1.1.17 (e). A valve insecurely mounted, leaking or defective.	1.6 (a). Malfunction indicator light, not working, not going through the correct sequence or indicates any kind of failure of the system.	1.6 (e). Removed or disabled.
LOAD SENSING VALVE	ELECTRONIC BRAKE SYSTEM	ELECTRONIC BRAKE SYSTEM
1.1.17 (e). A valve insecurely mounted, leaking or defective.	1.7 (a). Malfunction indicator light, not working, not going through the correct sequence or indicates any kind of failure of the system.	1.7 (e). Removed or disabled.
AXLES, WHEELS, TYRES AND SUSPENSION		
AXLES	WISHBONES AND SUSPENSION ARMS	AXLES
5.1.1 (g). Mounting bushes, bearing or bearing carrier, shafts, ball joints, obviously loose, worn or insecure.	5.3.3 (a) l. Wishbones, swinging arm, track control arm, suspension strut: attachment of component to chassis or axle is insecure or worn.	5.1.1 (d). Axle is obviously out of line.
SPRING (COIL/LEAF)	SPRING (COIL/LEAF)	AXLES
5.3.1 (j). A U-bolt is loose or missing.	5.3.1 (p). A spring centre bolt missing, damaged or broken.	5.1.1 (d). Axle is obviously out of line.

SUSPENSION JOINTS	WISHBONES AND SUSPENSION ARMS	SPRING (COIL/LEAF)
5.3.4 (a). Excessive wear in swivel pin and/or bushes or at suspension joints or a component is insecure or worn.	5.3.3 (a) I. Wishbones, swinging arm, track control arm, suspension strut: attachment of component to chassis or axle is insecure or worn.	5.3.1 (a). Spring/torsion bar mounting is obviously loose/broken, cracked or damaged.
TYRES	WHEELS	TYRES
5.2.3 (r) A tyre is incorrectly seated on wheel rim.	5.2.2 (e) A wheel is damaged such that tyre damage or seal damage can occur.	5.2.3 (q) Tyre(s) obviously underinflated and cannot be inflated.

CHASSIS, CAB AND BODYWORK

TRANSMISSION	TRANSMISSION	TRANSMISSION
6.1.7 (l). Propeller shaft or half shaft is damaged or bent.	6.1.7 (a). Loose or missing propeller shaft or half shaft securing bolts or nuts.	6.1.7 (f). Driveline component is liable to lock up or break away.

STEERING

STEERING GEAR CONDITION	STEERING GEAR CASING	STEERING LINKAGE
2.1.1 (d). Excessive wear or movement in sector shaft	2.1.2 (i). Axial or radial play is present in the linkage, splines are worn, or a shaft is twisted.	2.1.4 (a). Moving steering linkage fouling a fixed part of the chassis.

STEERING GEAR CONDITION	STEERING GEAR CASING	STEERING LINKAGE
2.1.1 (i). Bushes/bearings are excessively worn.	2.1.2 (i). Axial or radial play is present in the linkage, splines are worn, or a shaft is twisted.	2.1.4 (a). Moving steering linkage fouling a fixed part of the chassis.

STEERING LINKAGE CONDITION	STEERING LINKAGE CONDITION	STEERING LINKAGE CONDITION
2.1.3 (k). Track rod/steering arm is obviously deformed, loose or cracked.	2.1.3 (c). Excessive wear at joints.	2.1.3 (f). A drag link or the track rod ends are obviously worn or insecure (inner and outer).

POWER STEERING	POWER STEERING	POWER STEERING
2.1.5 (a). power assistance is not available consistently over full lock to lock range.	2.1.5 (c). power steering fluid below min.	2.1.5 (j). power steering pump is worn, noisy, leaking or has a defective drive.

STEERING

STEERING GEAR CONDITION	POWER STEERING	POWER STEERING	POWER STEERING
2.1.1 (h). Obvious oil leak (formation of drops).	2.1.5 (a). Power assistance is not available consistently over full lock to lock range.	2.1.5 (c). Power steering fluid level is below minimum level.	2.1.5 (j). Power steering pump is worn, noisy, leaking or has a defective drive.

AXLES, WHEELS, TYRES AND SUSPENSION

STUB AXLES	WHEEL BEARINGS	WHEEL BEARINGS	STUB AXLES
5.1.2 (b). Excessive wear in the swivel pin and/or bushes/bearings.	5.1.3 (a). Excessive play in a wheel bearing.	5.1.3 (e). Bearing(s) or hub are worn or damaged.	5.1.2 (f). Stub axle pin loose in axle.

Working To Save Lives

Údarás Um Shábháilteacht Ar Bhóithre

Road Safety Authority

Páirc Ghnó Ghleann na Muaidhe, Cnoc an tSabhaircín, Bóthar Bhaile Átha Cliath, Béal an Átha, Co. Mhaigh Eo

Moy Valley Business Park, Primrose Hill, Dublin Road, Ballina, Co. Mayo

locall: 1890 50 60 80 fax: (096) 25252 email: info@rsa.ie website: www.rsa.ie

ISBN 978-1-4064-2491-1

